

**FREE SHIPPING!**  
on orders over \$100

\*Contiguous United States



# PERFORMANCE PARTS GUIDE

Hotrod | Classic | Late Model | Import

toll free: 800.846.4252 online: [www.sksspeed.com](http://www.sksspeed.com)



@sksspeedracing



# Mark Your Calendar!



-4<sup>TH</sup> ANNUAL-  
**CAR SHOW**

**WHEN:**

**SATURDAY, JUNE 2ND 2018**

Rain Date June 3<sup>rd</sup>

**WHERE:**

**OUR LINDENHURST SUPERSTORE**  
1075 RT. 109 LINDENHURST, N.Y. 11757



**SK SPEED BRANDED CLOTHING & APPAREL**

**"Marque" Line T-Shirts** - Featuring various SK Speed branding from over the years these t-shirts are perfect for the customer who wants to represent our rich history of serving the greater Long Island, NY area since 1963! UNISEX Tees are available in sizes M - 2XL and start at \$14.99 each!

**"Vintage Series" T-Shirts**

These special-edition, limited-run shirts feature some of the iconic SK Speed drag cars from the track through the years past!

**"Anglia" Tee** - Featuring our 1949 Anglia that ran 10.90's @ 129mph from 1964 through 1967 at tracks like New York National Speedway, Old Bridge Township Raceway Park, & Islip Speedway.  
Sizes S - 2XL Starting at \$19.99



**COMING SOON!**

**"Avenger Dart" Tee Coming Soon!**

**"Dyno Ram"**  
Back Shown



**"Comp. Eng."**  
White or Black  
Back Shown



**"2012 Logo"**  
Back Shown



**"2017 Logo"**  
Back Shown



**"Anglia" Tee**  
Back Shown



**STICKERS & DECALS**

Represent SK Speed on your street or track vehicle with a magnitude of vinyl decals to choose from. Available in windshield and window/fender sizes.



**GIFT CARDS**

Choose from 3 different gift card styles! Perfect for family, friends, & auto enthusiasts alike! Gift cards can be purchased in any amount you desire, with no expiration dates!

**Card Sleeves**  
Now Available!



# NEW PRODUCTS

NOW IN-STOCK AT SK SPEED



REV™ STREET PERFORMANCE & RACING DRIVESHAFTS



## 2005-2017 MUSTANG

These REV™ Series Carbon Fiber Driveshafts are direct bolt-in. Designed & wound specifically for S197 & S550 Ford Mustangs, they feature the same high quality materials & benefits as the rest of the REV™ Series driveshafts.

Engineered for up to 1500 HP with a max rated torque of 1000 lb\*ft, QA1's Mustang driveshafts feature Spicer Life Series 1350 U-joints, & utilize a high speed CV joint with a high speed sealing boot & high temp grease. This high speed capability allows to minimize effects of NVH while increasing performance.



Application	With SFI	Without SFI
05-10 Mustang GT	JJ-21209	JJ-21214
11-14 Mustang GT	JJ-21210	JJ-21215
15-17 Mustang GT, Manual	JJ-21207	JJ-21212
15-17 Mustang GT, Automatic	JJ-21206	JJ-21211
15-17 Mustang, Shelby GT350	JJ-21208	JJ-21213



## 2015-2017 CHALLENGER SRT HELLCAT

These bolt-in REV™ Series Carbon Fiber Driveshafts are designed & wound specifically for Challenger SRT Hellcats with up to 1500 HP & a max rated torque of 1000 lb\*ft. They feature the same high quality materials & benefits as the rest of the REV™ Series driveshafts.

QA1's Challenger Hellcat driveshafts feature Spicer Life Series 1350 U-joints, & utilize a high speed CV joint with a high speed sealing boot & high temp grease. This high speed capability allows us to minimize effects of NVH while increasing performance. They also offer a 27% weight savings over stock two-piece driveshafts, while their 3.3" diameter tube provides better clearance for exhaust systems.



Application	With SFI	Without SFI
15-17 Challenger SRT Hellcat, Manual	JJ-23203	JJ-23201
15-17 Challenger SRT Hellcat, Automatic	JJ-23202	JJ-23200



Hellcat Challenger Factory 2-Piece Driveshaft VS QA1 Carbon Fiber.



# QA1® C10 SUSPENSION COMPONENTS



## FRONT COIL-OVER SYSTEM

### UPPER & LOWER ARMS FOR USE WITH STOCK SPRINGS

Want to use a factory style spring with the shock in the factory location of your 1963-1987 C10? QA1 offers front upper & lower control arms for use with stock springs. They feature QA1 performance ball joints & low friction, maintenance-free polymer bushings. These arms utilize the same design features of the front control arm & shock kit; adding stability with 7 degrees of caster when used together, combined with an offset cross shaft in the upper arm, letting you quickly & easily adjust camber. This optimum camber adjustment allows you to get the most out of modern performance tires. These control arms are sold in pairs & include all necessary hardware.

### UPPER & LOWER ARMS WITH PRO COIL SYSTEM

Designed for use with QA1 Pro Coil Systems, these kits include your choice of QA1's proven single or double adjustable coil-over shocks so you can change the valving to meet your specific needs, along with a variety of high travel spring rate options. These shocks allow for ride height adjustability & are 100% dyno tested & serialized. Coil-over hardware & all required nuts, bolts, etc. are included. Compatible with popular drop spindles, which will provide even more drop when used with this system.

## C10 REAR SUSPENSION SYSTEMS

QA1's C10 bolt-on rear suspension system is designed to convert trucks originally equipped with a coil-spring rear suspension to coil-overs. This system relocates the coil-overs to the outside of the frame rail, closer to the wheel, providing more cornering stability & allowing room for popular aftermarket rear fuel tanks.

**KIT INCLUDES:**  
Adjustable Shocks  
High Travel Springs  
Coil-over Hardware

Truck Arms  
Panhard Bar & Brace Bar  
C-Notch Kit (Optional)  
All Required Nuts, Bolts



DISC BRAKES  
**wilwood**

## C10 PRO SPINDLE KITS

Wilwood's ProSpindle Kits contain a pair of Modular Spindles, steering arms & hubs assemblies for either 63-70 or 71-87 Chevrolet & GMC 2WD C10/ C15 Pickups & Suburban's. Specifically designed for use with Wilwood's disc brake kits, with a 2.50" drop for a more aggressive stance without affecting steering geometry.

**Supports both 5 x 4.75" & 5 x 5.00" wheel bolt circles.**



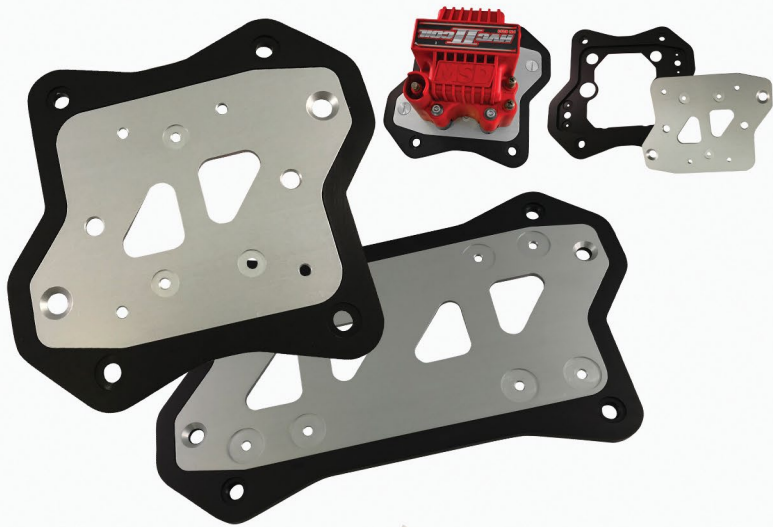

## MSD IGNITION COIL & BOX BILLET MOUNTING BRACKETS

PRP's new MSD Ignition & Coil Mounting Brackets take the guess work out of mounting your coils. Each part is made of two pieces, a frame work, & insert. The frame is permanently mounted while the insert can be removed with a twist of two dzus clips. This bracket is made of 6061 aluminum & two tone anodized for a great finish. Will work with MSD Blaster, MSD SS, & MSD HVCLL coils as well as all MSD 6AL, 7AL, 8AL, 9AL, & 10AL ignition boxes



## LS BILLET ELEC. WATER PUMPS

Each pump is machined from one piece of solid 6061-T6 billet aluminum, & utilizing all the top components from our current line of water pumps. Features include a heavy duty electric motor for high flow, carbon ceramic seal for positive sealing, o-ring inlets for easy assembly, & o-ring mounting for quick installation. Each unit is complete with anodized finish, & comes with stainless mounting hardware.

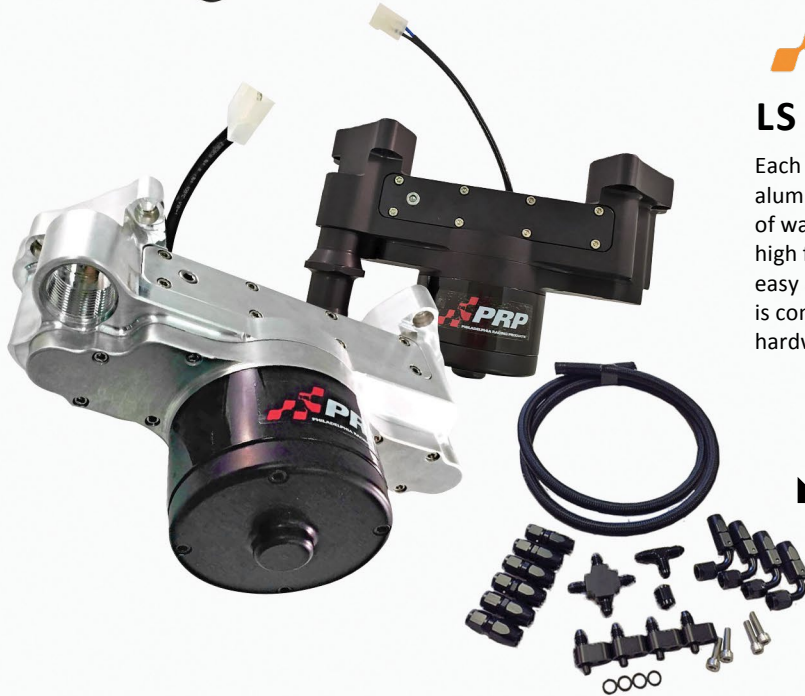

Available in **Clear & Black**  
Anodized Finishes

### LS COOLANT CROSSOVER KIT

PRP's new plumbing kit includes all of the necessary parts to complete a 4 corner water crossover on your LS engine. Each kit comes complete with #4 hose & #4 fittings to fully plumb your kit the way you want it. All necessary hardware & O-rings included.



## BILLET FLEXPLATES



PRP's new aluminum flexplate is probably the most unique plate on the market. Each plate is machined to accept the 168 tooth replaceable steel ring gear that is pressed & bolted on with six 1/4"-20 stainless button head bolts. This plate is machined to fit small block & big block Chevy, & will work with all convertor applications.



## BILLET INTERCOOLER CAPS



No need to fight getting ice into your intercooler again! With PRP's new billet machined extra-large filler caps it is not a problem at all. These one of kind extra-large caps offer almost a 7" opening & are sealed with a BUNA-N O-ring for a water tight seal. Two available styles complete with stainless steel hardware in either a weld on version, or bolt on version.





Titanium has long been used in the Aerospace & Motorsports industries due to its outstanding strength to weight ratio. These characteristics make Titanium the ideal raw material for professional fabricators looking to build durable & ultra-lightweight high performance induction & exhaust components that can stand up to the rigors of racing. Best of all, Vibrant makes Titanium more affordable than it has been in the past.

**MUFFLERS & RESONATORS**

- Manufactured entirely from CP1 Grade Titanium.
- "True Straight Through" perforated Titanium core ensures unrestricted exhaust flow.

**STRAIGHT & MANDREL BENDS**

- CP1 grade Titanium. Straight sold in 1 meter (39.4") lengths. Bends sold in 2.5", 3", 3.5" diameters, 45° & 90° available.
- Straight .039" thick tubing; Mandrel Bend .047" thick tubing.

**PIE CUTS**

- Precision Laser Cut.
- CP1 grade Titanium.
- 1.0mm (0.039") thick.
- 5 Pie Cuts at 9° each = 45° elbow.

**WELD-IN BUNGS**

- O2 Bung (tapped M18 x 1.5).
- EGT Bung (tapped 1/8"-27 NPT).

**WELD TAB SET**

- Titanium Weld Tabs.
- Stainless Steel Spring.

**FiTech** *RETRO LS*  
**Fuel Injection** **THROTTLE BODY EFI KIT**

FiTech offers all the features of the Ultimate LS Kit – automatic trans control, 24x or 58x reductor wheel adjustability, timing control with coil pack drivers, & fueling control with the four injectors in a classic gold 4-barrel throttle body for an old school look.

FiTech's Retro LS is a complete throttle body kit, suitable for that junkyard 5.3 to a stroker 427, All you need to do is add your intake & LS engine.

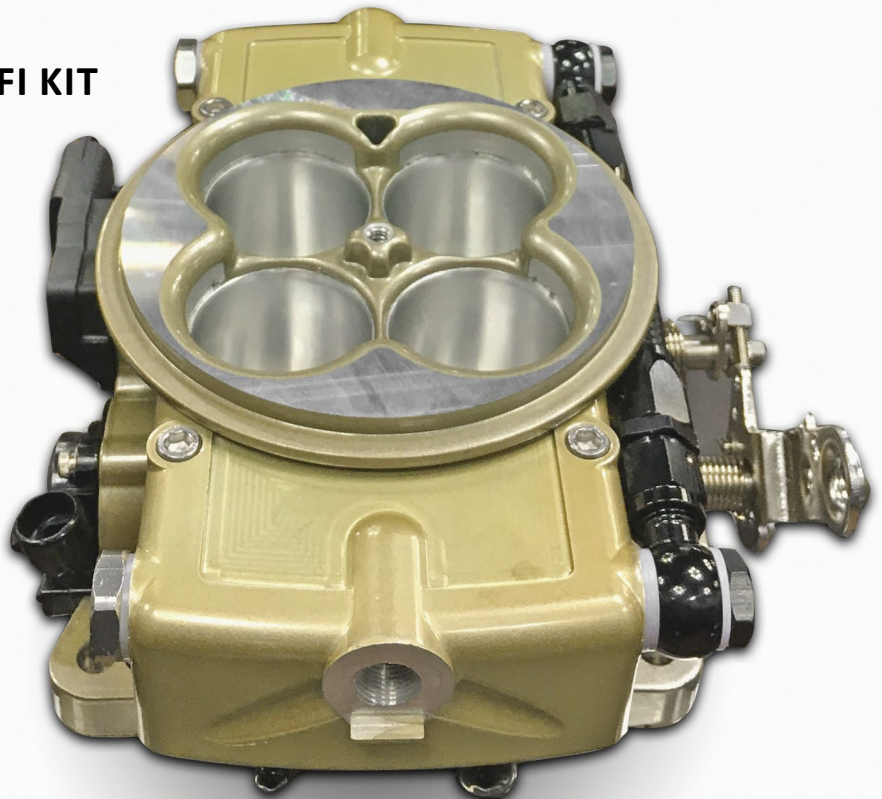

**OLD SCHOOL  
FINISH!**



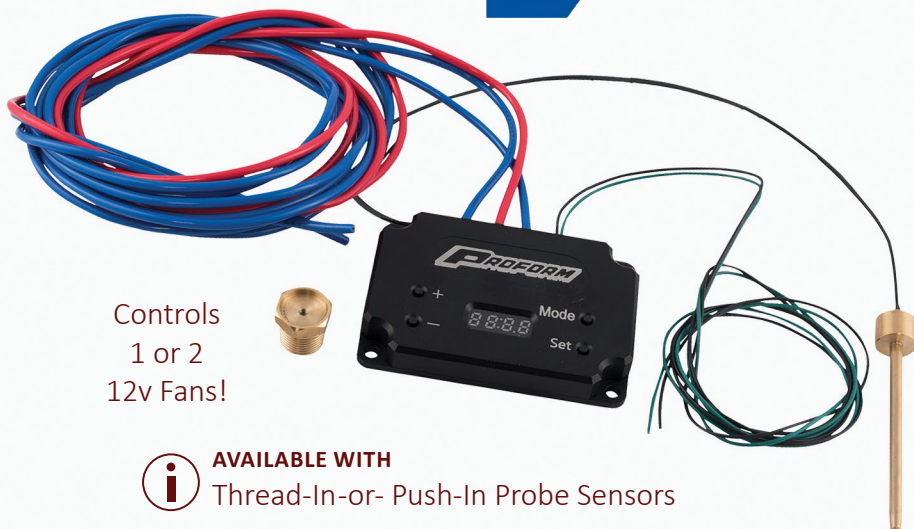

Controls  
1 or 2  
12v Fans!

**AVAILABLE WITH**  
Thread-In-or- Push-In Probe Sensors

## VARIABLE SPEED FAN CONTROLLER

This variable speed fan controller makes the fan or fans run at whatever speed is needed to maintain a consistent temperature. The controller receives a temperature signal from the radiator with either a push-in, or thread-in brass probe. The fan controller processes the signal & runs the fan(s) at the correct speed needed to maintain the desired temperature. The weather resistant billet aluminum housing with bright digital display ensures easy setting by simply pushing + or - to set temperature.

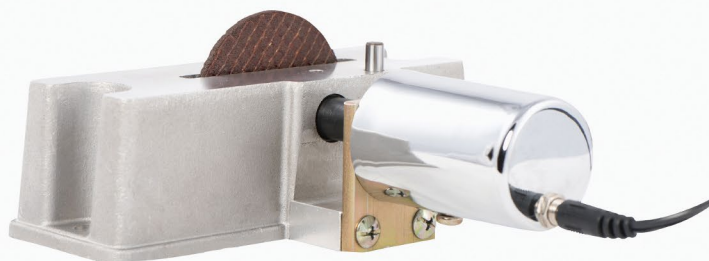

## ELECTRIC PISTON RING FILER

Accurately set end gap with PROFORM's powerful electric ring filing tool. Powered by a 12 volt, rechargeable battery. Offers maximum speed & affordability. Comes with two (2) 120-grit grinding wheels (p/n 66762) & battery recharger. Portable or can be bench mounted.



## HARMONIC BALANCER INSTALLATION TOOL KIT

One tool set to install just about any balancer out there, with 12 adapters to fit a variety of applications, this one-stop shop kit will allow a builder to keep everything together in a neat & organized way. Roller thrust bearing included to reduce friction. Plastic molded storage case included. Included adapters are as follows: 7/16-20, 1/2-20, 9/16-18, 5/8-18, 3/4-16, M12-1.75, M12-1.5, M10-1.5, M14-1.5, M14-1.5, M16-2.0, & M16-20.



## PNEUMATIC VALVE SPRING COMPRESSOR

Cut cylinder head assembly & disassembly time in half with the Proform pneumatic valve spring compressor. Builds 350 lbs. of force with 125 psi, & will operate on a minimum of 100 psi. The compressor arm slides for adjustment, employing a locking pin for rapid, easy installation. Works on most cylinder heads.



## DOUBLE-END AN WRENCH SET

Proform's latest four piece AN wrench set has both a 30 & 60 degree head to grip hose ends from a wider array of positions & in some if the tightest of spaces. Color coded sizes, Blue: -6AN, Gold: -8AN, Red: -10AN, Black: -12AN. Includes durable, nylon carrying case!





## BRUSHLESS SERIES A1000 FUEL PUMPS

### Brushless External Inline Pump

The Brushless A1000 has a flow rate of 1.8 GPM @ 60 psi @ 13.5VDC with -10 AN inlet & outlet. It is available as an external in-line option, #11124, or direct drop-in, #18023. The A1000 is also available as a complete fuel cell in either a 6 gallon #18366, 15 gallon #18360, or 20 gallon #18361 capacity.

- -10AN inlet & outlet ports.
- For EFI applications use regulator P/N 13303 or P/N 13139.
- For carbureted applications use regulator P/N 13204 or P/N 13304.
- Fully submersible for custom, in-tank placement. Perfect for 'blow-through' carbureted engines up to 1200 FWHP.



— BRUSHLESS —  
**A1000**



-10AN

#### FUEL INJECTED ENGINES:

- up to 1300 HP – naturally aspirated
- up to 1000 HP – forced air induction

#### CARBURETED ENGINES:

- up to 1500 HP – naturally aspirated
- up to 1200 HP – forced air induction



### PROMAX DUAL CHANNEL PROGRESSIVE CONTROLLER

The Nitrous Outlet ProMax is the most capable progressive nitrous controller on the market! Built in 70amp solenoid drivers control 2 independent stages, or a single stage with closed loop fuel adjustment based on wideband input. Ability to datalog, internal storage for up to 5 different tuneups, setup via PC or optional display, 2 ignition retard outputs, adjustable frequency output, multi-gear lockout function, resume and re-start feature, and so much more.

- ProMax Progressive Controller, 20 Pin Connector, Flash Drive & USB Cable
- Updateable Firmware
- Controller can be programmed via PC/laptop or optional display.





## SNIPER EFI 1 INCH DROP BASE

Complete your Sniper EFI install with Holley's 1 Inch Drop Base to gain some extra under-hood room! The Sniper EFI air cleaner drop base was designed specifically for use with the Sniper EFI 4BBL throttle body & a 14" air cleaner element & lid. These stamped steel drop bases feature a generous 1" drop with the necessary clearance bulges for use of the front mounted fuel inlets on the Sniper EFI unit.

Available in  
**Black & Chrome** Finishes!

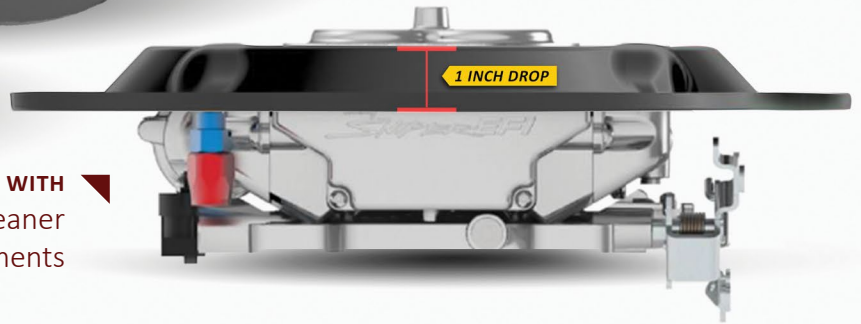

DESIGNED FOR USE WITH  
14 Inch Diameter air cleaner  
filter elements



## EXHAUST CUT-OUT DUAL KIT W/REMOTE

Good & "old" ideas improved with new materials, that's what we have here. Hooker Electric Cut-outs open & close with a flip of a toggle switch or via the included key fob remote. A mixture of T-304 stainless steel & 6061 aircraft aluminum will provide years of worry free use. The materials will keep the elements out, & the sound... Well that's up to you.



## WEATHERPACK 3-PIECE TOOL KIT

These pin extraction tools work on weatherpack, weather-tite, & many OEM (GM, Ford, & Chrysler) connectors. Designed to release & extract the terminals from the connector housing when wiring or repairing your vehicle. 3-piece set with a narrow pick, wide pick, & tubular shaped extraction tool!





## Easy Loom Master Kit

DEI Protective Easy Loom Split Sleeves offer a clean solution to protect exposed wires, cables & hoses on trucks, SUV's & powersport vehicles including ATVs & UTVs. Superior in style & function to simple plastic tubing, DEI's Split Sleeve design adds a superior level of protection to sensitive wires cables & hoses exposed to abrasion or the elements; all with a clean, classy look.

### Master Kit Includes:

- 1" x 6' Loom
- 3/4" x 10' Loom
- 1/2" x 30' Loom
- 5/16" x 60' Loom
- 3/16" x 15' Loom
- 3/8" x 2' Heat Shrink
- 1/4" x 1' Heat Shrink
- 1/2" x 1' Heat Shrink
- (40) 8" Ties
- (100) 4" Ties
- Electrical Tape
- 1" x 12' Silicone Tape



D40010663



## Black Titanium Exhaust Wrap Kits

Black Titanium exhaust wrap, with LR Technology, is made from pulverized lava rock, stranded into a fiber material then woven into a proprietary weave. Titanium wrap is engineered to be stronger than most wraps & more durable for improved thermal performance & reliability.

- Extremely pliable for tight & secure wrap
- Withstands 1800°F direct / 2500°F intermittent heat
- Black carbon fiber look
- DEI HT Silicone coating not required
- Pre-wetting roll not necessary for wrapping

D40010003



Available for  
T3 & T4

## ONYPX™ Series Turbo Shield Kits

Building on the popularity of the ONYPX™ Series, DEI has expanded its turbo shield offerings to include a GT 22 & GT25 sized shields that utilize this high performing material. Unlike cheap, knock-off copies, the DEI Turbo Shields are Made in the USA, using an exclusive combination of premium heat resistant textiles & newly designated stainless steel attachment anchors.

- Turbo Shield
- 2" x 25 ft roll of Black wrap
- Eight 14" stainless steel zip ties & 5' of fastening wire

T4- D40010182 | T3 - D40010180



## Heat Shroud GOLD™

The DEI Heat Shroud GOLD™ line & hose sleeving will protect & keep components cool in the most demanding applications. Able to reflect direct heat up to 800°F. Heat Shroud GOLD™ includes the added convenience of hook & loop closure with open edges.

D40010458



## Vapor Block™ Fuel Line Sleeve

Line sleeving specifically developed to prevent vapor lock in fuel systems. Its excellent thermal effectiveness comes from glass fiber & polyester laminated to an aluminum outer layer. Split design with adhesive flap.

D40010669



## Grommet Locking Tie Kit

When mounting heat shields or other materials it can be difficult to make it look professional. Kit includes 24 - 3/8" grommets, grommet eyelet tool, Six 20" long stainless locking ties & a handy locking tie tightening tool.

D40010223



RED  
M467564

BLACK  
M467563



WRE73568

## STAND ALONE SOLID STATE RELAY

This module takes the place of 4 standard relays & eliminates unsightly wiring. 4 independent channels can be activated using either power or ground. Each channel is capable of handling up to 20 Amps of continuous current providing up to 80 Amps of power. Controls electric fans, water pumps, nitrous solenoids, auxiliary lighting & any other electrical accessories that would normally require a relay.

## 4-WAY MINI RELAY BLOCK KIT

The 4-way mini relay holder is ideal for protecting relays against dust, debris & liquids that can hinder relay performance. The relay block allows for a professional installation where multiple 5-pin relays can be mounted cleanly. The 4-way mini relay holder block kit includes everything needed for immediate installation, just add up to four mini style relays.



## BORN FROM JOE GIBBS RACING DRIVEN FR50 + SR50 Racing Oil

FR50 high performance motor oil is formulated specifically for Ford Coyote engines. It utilizes next generation synthetic oil technology to provide unmatched performance & protection in high temperature, high shear environments.

Ideal for race engines requiring a 20W-50 weight motor oil, SR50 provides consistent protection for flat tappet engines & prevents lifter skidding in aggressive roller cam valve trains using both needle & bushing lifters.

## Valvoline PRO-V Racing Oil

PRO-V Racing Oil is born out of Valvoline's Professional Racing Partnerships

- Recommended for V8 engines used in sprint & midget racing.
- For use in grassroots racing when OEM recommends a 0W-30 viscosity.
- Designed for engines with clearances between 0.0020" & 0.0025".
- Lowers oil vaporization & consumption in extreme conditions.





## PERFORMER SERIES CARBURATORS

Edelbrock's Performer carburetors feature two-piece, all-aluminum construction for cooler operating temperatures & less warping. There are no gaskets below the fuel bowl level for fewer leaks, & no plastic parts or power valves to blow out. The carbs use easily changed metering rods for precise tuning, & the primary venturi booster is a bottom-feed design for smoother acceleration & better drivability.

### 500 CFM MANUAL/ELECTRIC CHOKE

Designed & calibrated for **small cubic-inch engines** such as 305 c.i.d & smaller Chevrolet; 302 c.i.d. & smaller Ford & dual-quad applications.

**Metering Jets:** Primary .086; Secondary .095

**Metering Rods:** .065 x .052

**Step-Up Spring:** Orange (5" Hg)

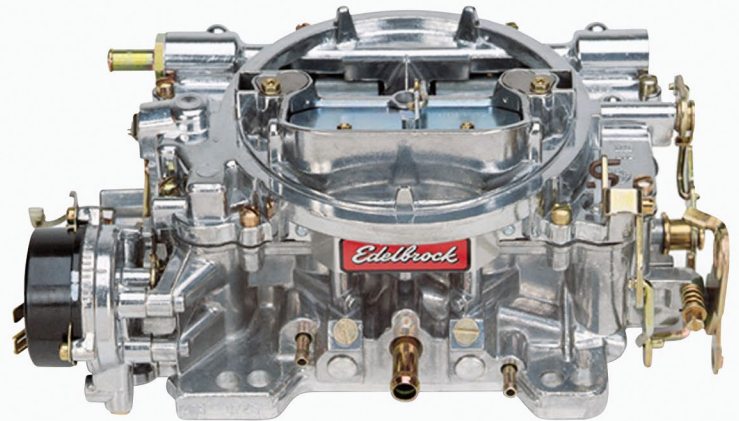

### 600 CFM MANUAL/ELECTRIC CHOKE

Designed & calibrated for **optimum street performance in small-block & some big-block engines**. Includes both timed & full vacuum ports for ignition advance.

**Metering Jets:** Primary .100; Secondary .095

**Metering Rods:** .070 x .047

**Step-Up Spring:** Orange (5" Hg).

Available Finishes: **Satin** | **Black** | **EnduraShine**



### 750 CFM MANUAL CHOKE

Designed & calibrated for **optimum street performance in small-block & big-block engines**. Includes both timed & full vacuum ports for ignition advance.

**Metering Jets:** Primary .113, Secondary .107

**Metering Rods:** .071 x .047

**Step-Up Spring:** Orange (5" Hg)

Available Finishes: **Satin** | **Black**

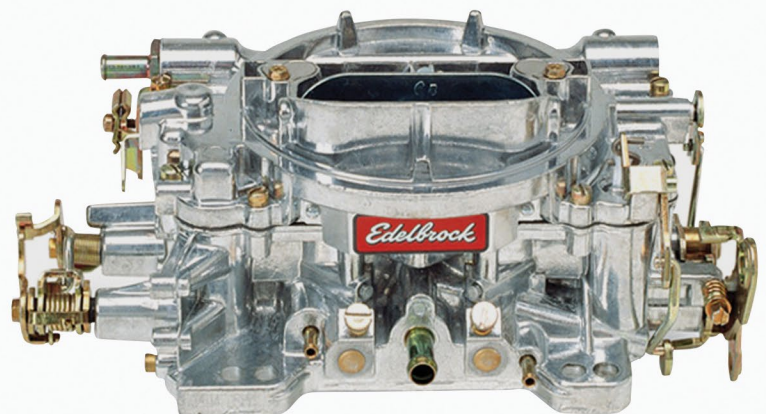



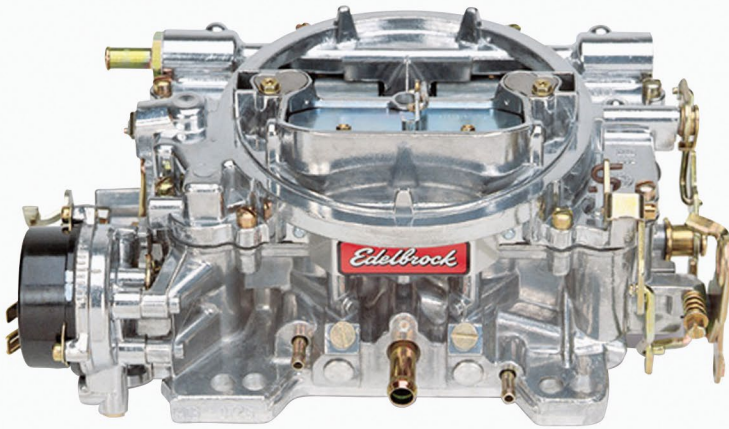

## 750 CFM ELECTRIC CHOKE

Designed for 402 c.i.d. & larger engines with Edelbrock Performer manifolds or other brands of similar design. Provides excellent fuel economy when used on 454 c.i.d. Chevy & 460 c.i.d. Ford with Performer manifold.

**Metering Jets:** Primary .110; Secondary .107

**Metering Rods:** .075 x .047

**Step-Up Spring:** orange (5" Hg)



## THUNDER SERIES AVS CARBURATORS

All of the performance features of Edelbrock's Performer carburetors, with an added twist--the Qwick Tune secondary air valve. This air valve can be easily adjusted to kick in the secondaries early or late--no extra springs are needed.

These CNC-profiled, ball-burnished aluminum carbs feature black accented hardware & GM/AMC throttle linkage.



## 650 CFM

## MANUAL/ELECTRIC CHOKE

Designed & calibrated for optimum street performance in small-block & some big-block engines. Match with a variety of manifolds that include Edelbrock Performer, Performer EPS, Performer RPM, RPM Air-Gap, Torker II or other brands of similar design.

**Metering Jets:** Primary .095, Secondary .098

**Metering Rods:** .068 x .047

**Step-Up Spring:** Orange (5" Hg)

Available Finishes: **Satin** | **Black**



## MARINE SERIES CARBURETORS

## 600 CFM ELECTRIC CHOKE

Designed & calibrated from Edelbrock for use in marine applications such as small-block V8 engines with a variety of manifolds.

These Edelbrock carbs comply with U.S. Coast Guard safety standards. Cast surfaces are protected by a Chromate conversion coating which is used as a corrosion inhibitor.

**Metering Jets:** Primary .086, Secondary .095;

**Metering Rods:** .065 x .052;

**Step-Up Spring:** orange (5" Hg).

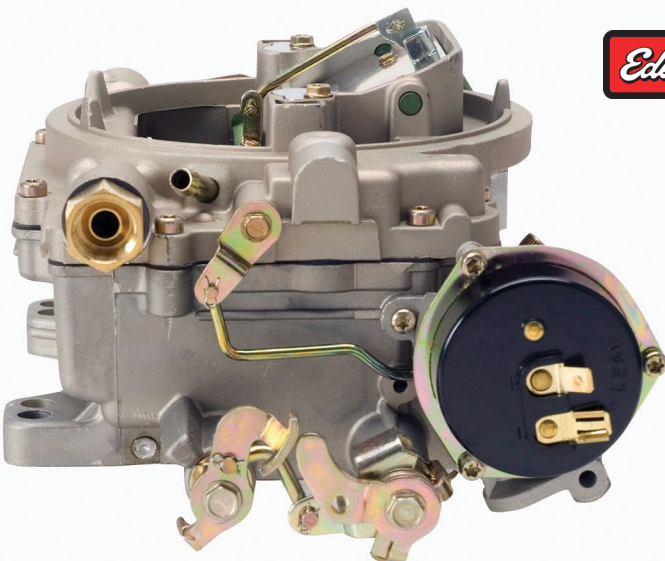



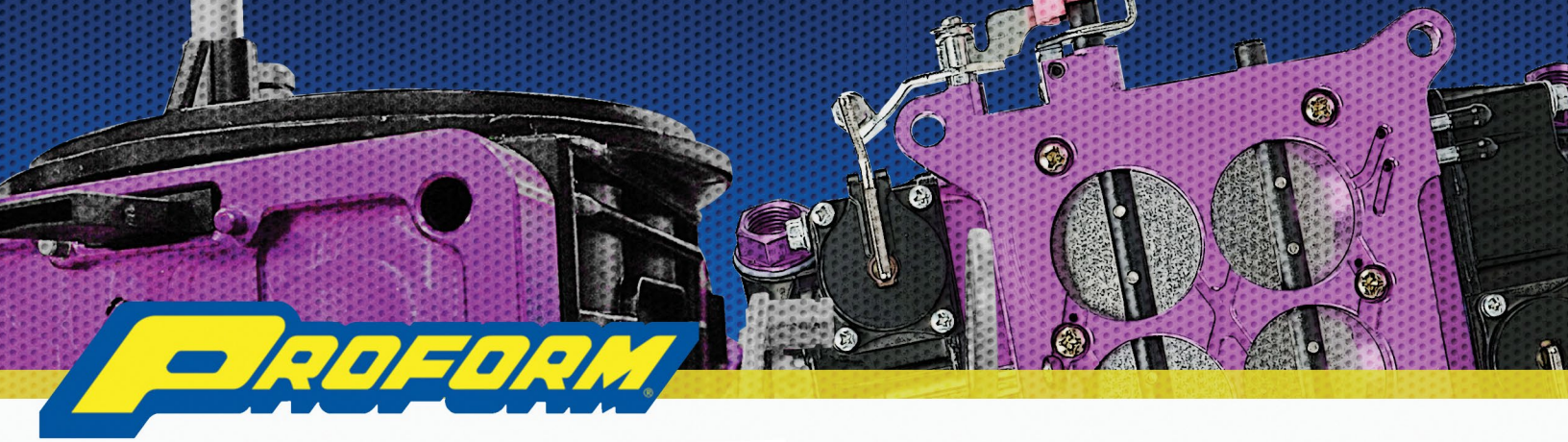

## STREET SERIES CARBURETORS

Based on the wildly successful Race Series carburetors the new Proform street carburetors are constructed of lightweight aluminum. They feature changeable idle air bleeds for easy non-permanent calibration changes if needed. This means you can keep your drills in your tool box because fine tuning is accomplished by simply changing air bleed.

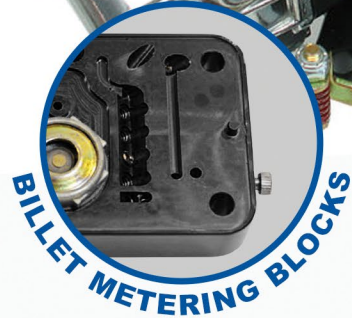
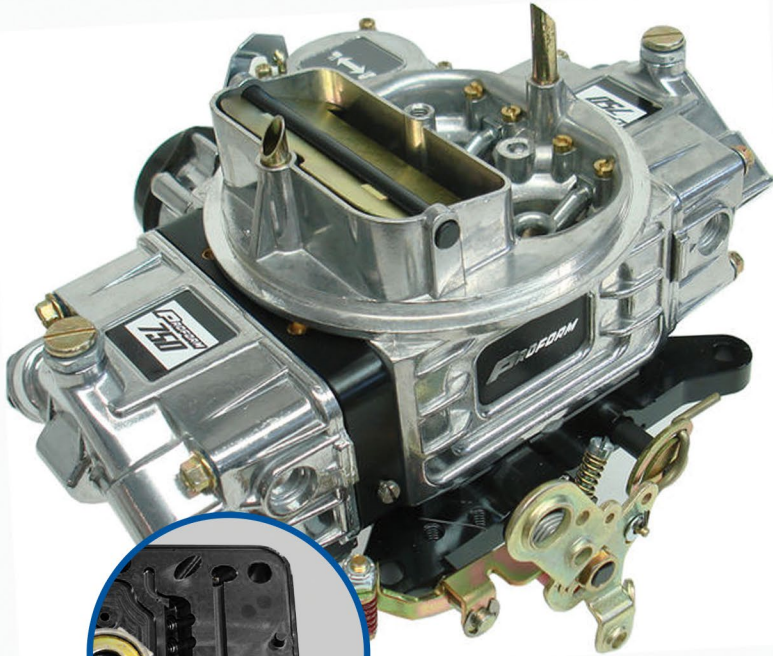

**650**  
CFM

**750**  
CFM

**850**  
CFM



VACUUM  
SECONDARY



MECHANICAL  
SECONDARY

## 650 CFM UPGRADE SERIES

Same great performance as the Street Series, this value package is completed with high quality, light weight die-cast aluminum fuel bowls with fuel level windows for quick visual reference. Float level changes do not require removal of a sight plug with the risk of fuel spilling all over the top of your engine. Bowls come equipped with 3/8" inverted flare fuel inlet fittings & will accept all conventional dual feed fuel lines compatible with Holley® four barrel carburetors.

**650**  
CFM



MECHANICAL  
SECONDARY

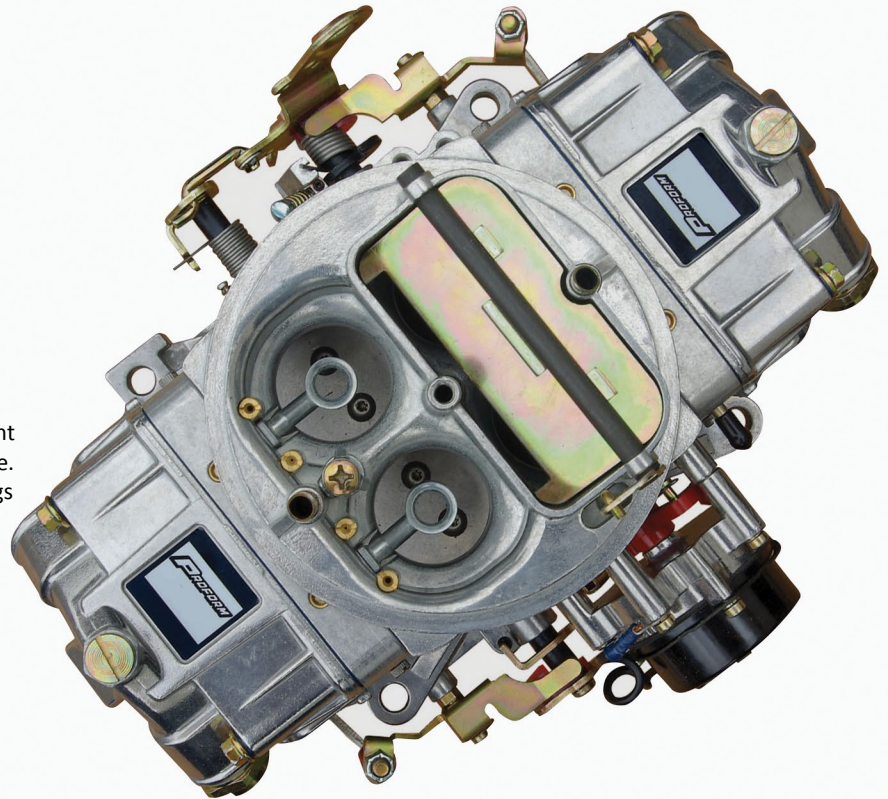





## RACE SERIES CARBURETORS

Proform offers a variety of affordable, high performance race carburetors assembled by hand in the USA. Utilizing the Proform high-flow main body, durable billet metering blocks & billet throttle base plates.

650  
CFM

750  
CFM

850  
CFM

950  
CFM

1050  
CFM



VACUUM  
SECONDARY



MECHANICAL  
SECONDARY

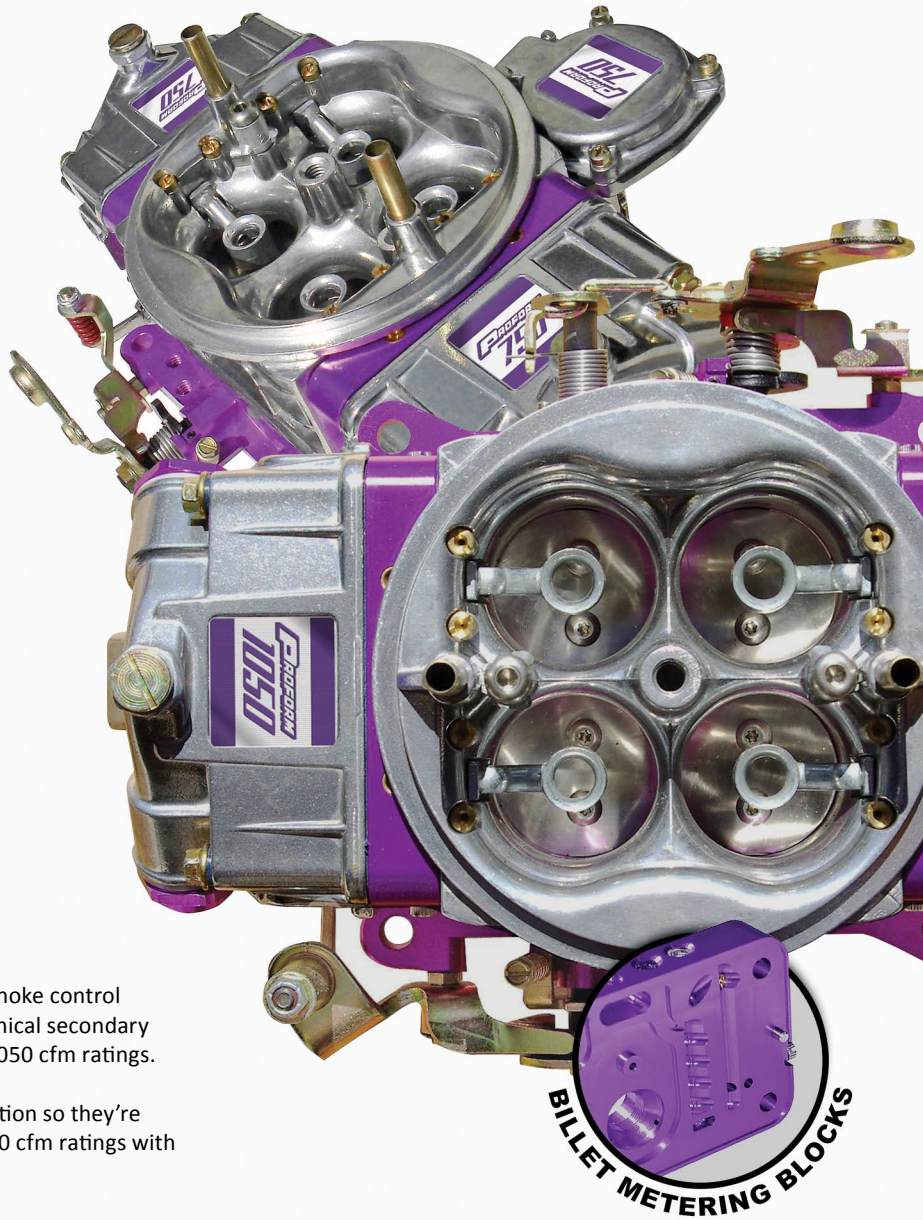

## BLACK RACE & STREET SERIES

The Race Series carburetors have the air horn, choke tower, & choke control removed for maximum airflow, plus progressive slip-link mechanical secondary linkage. The carburetors are available in 650, 750, 850, 950, & 1050 cfm ratings.

The Street Series carburetors have a street performance calibration so they're ready to run out of the box. They are available in 650, 750, & 850 cfm ratings with vacuum secondaries.



Black Diamond PTFE coating reduces fuel temperature up to 6% & resists corrosion.

Newly designed throttle lever with integrated Ford A/T kickdown, GM 700R4 mounting holes, & the ability to mount brackets for Chrysler vehicles.

650  
CFM

750  
CFM

850  
CFM

950  
CFM

1050  
CFM



VACUUM  
SECONDARY



MECHANICAL  
SECONDARY



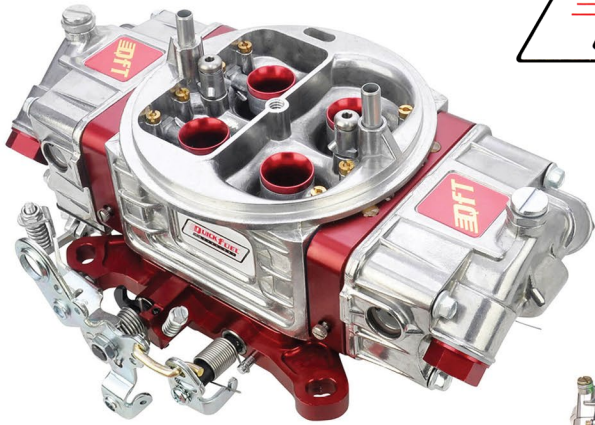

## DRAG Q SERIES

**650CFM | 750CFM | 850CFM | 950CFM | 1050 CFM**

*Mechanical Secondary*

Ideally suited for bracket racers & weekend warriors alike, Q-Series carburetors are purpose-built for the dragstrip. To combat the g's experienced during hard launches, Q-Series carbs are equipped with notched floats & secondary jet extensions.



**DEVELOPED/CALIBRATED FOR USE WITH E85**

**650 CFM | 750CFM | 850CFM | 950CFM | 1050CFM**

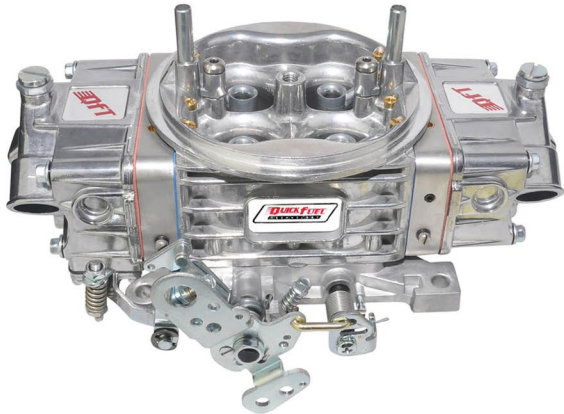

## STREET Q SERIES

**650CFM | 750CFM | 850CFM | 950CFM**

*Vacuum & Mechanical Secondaries*

Quick Fuel Technology's new Street-Q carburetor is intended to deliver legendary Q-Series performance to hardcore street enthusiasts at a reduced price. The major differences between the Street-Q & the race-bred Q-Series is the substitution of cast metering blocks & a cast throttle body in place of fully-machined billet components.



## SS SERIES

**650CFM | 735CFM | 750CFM | 850CFM**

*Vacuum & Mechanical Secondaries*

Super Street Series carburetors combine street-friendly drivability & track-capable performance in a single value-oriented package. Setting them apart from ordinary street carbs, they feature billet dual metering blocks & throttle-bodies that offer tighter tolerances & eliminate porosity. Not only are Super Street Series carbs available with both vacuum or mechanical secondaries, QFT™ also offers models designed & calibrated specifically for E85 fuel & blow-through forced induction applications.

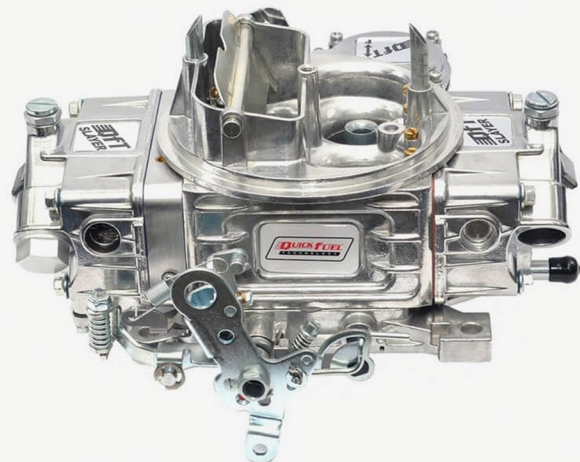

## SLAYER SERIES

**600CFM | 750CFM**

*Vacuum Secondary*

Slayer Series street carburetors are designed with many of the same innovations & features that are built into all QFT™ race-winning carburetors, including changeable air bleeds & power valve channel restrictions. It's designed with a secondary metering plate with changeable jets, & features all aluminum components for additional weight savings.





# CLASSIC CARBURETORS



2BBL

MANUAL CHOKE

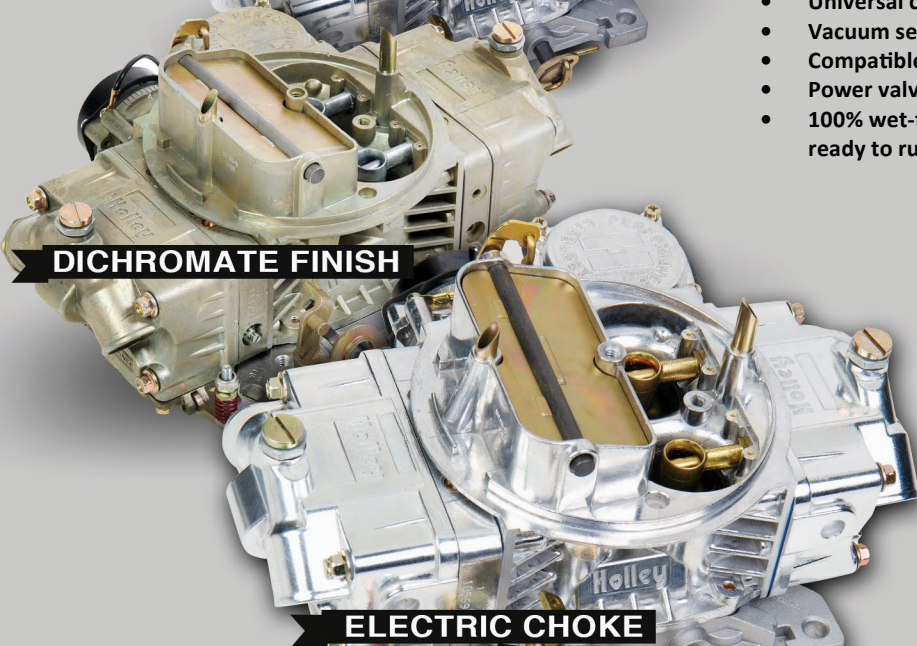

DICHROMATE FINISH

ELECTRIC CHOKE

Performance upgrade for stock to mildly modified engines with classic Holley looks. Available single fuel inlet or dual feed inlets! Vibratory polished aluminum for good looks, weight savings & long lasting shine.

- Universal calibration for easy bolt-on performance
- Vacuum secondaries for use on wide variety of vehicles.
- Compatible with GM, Chrysler, & Ford A/T kickdown linkage.
- Power valve blow-out protection
- 100% wet-flow tested by Holley technicians to assure it arrives ready to run!

500  
CFM

600  
CFM

650  
CFM

750  
CFM



VACUUM  
SECONDARY



MECHANICAL  
SECONDARY

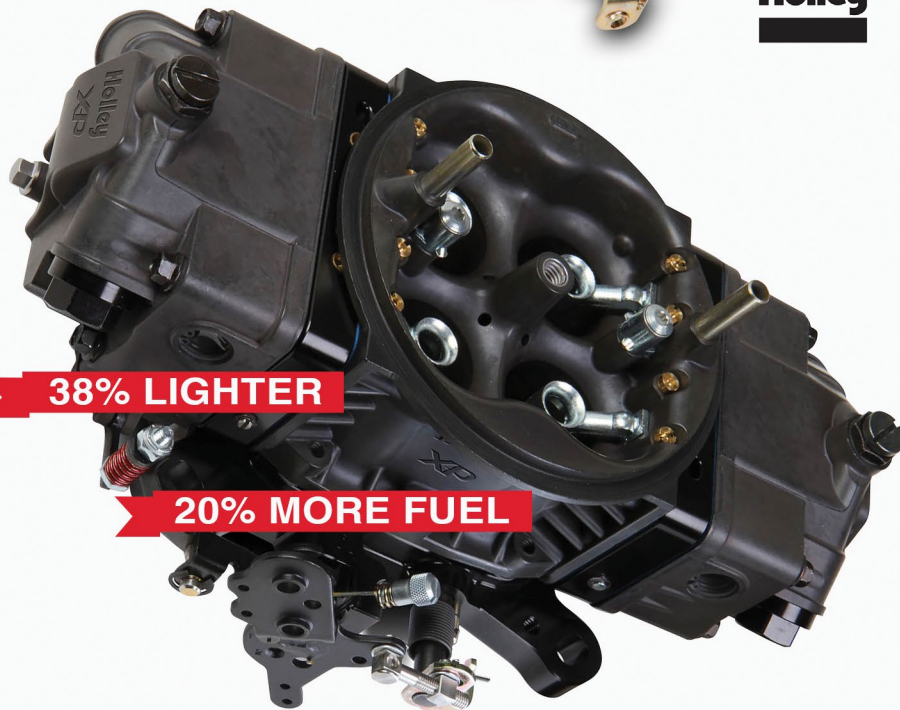

38% LIGHTER

20% MORE FUEL



## ULTRA XP CARBURETORS

Holley Ultra XP carburetors offer new features such as an integrated idle bypass valve that allows for idle adjustments while maintaining the correct throttle plate to transfer slot relationship, high capacity fuel bowls which feature 20% more fuel capacity to eliminate starvation, integrated fuel shelf to minimize fuel aeration & internal baffling to control fuel slosh. Other features include all aluminum construction, fully tunable billet metering blocks, billet base plate, adjustable secondary linkage & knurled (hand adjustable) curb idle screws. Holley Ultra XP carburetors are the ultimate in square bore race carburetors!

500  
CFM

600  
CFM

650  
CFM

750  
CFM

850  
CFM

950  
CFM



MECHANICAL  
SECONDARY



## CARBURETOR STUDS

Nut & Washer Kits



1-1/2"  
E118008

1-3/4"  
E118024

Bullet Tip 1-1/2"  
E118056



1-3/8" - G1259

1-1/2" - G1260

2" - G1261

2-1/2" - G1262

Bullet Tip 2"  
G126346G



Overall Length  
3-5/16"

5/16" Course/Fine  
Threads

RPCR0977

## CARBURETOR SPACERS/ADAPTERS



### 1" Carb Spacer

Plastic - M2864940  
Billet - M2864951



4-HOLE 1"  
RPCR9134



### Open Spacer 4150 4160

Carburetor Phenolic Studs & Gaskets

1/2" - RPCR9139 1" - RPCR9136  
2" - RPCR9137

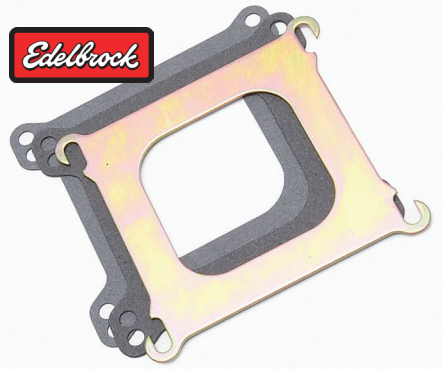

### Spread-Bore Adapter

Mounts square-bore carbs to spread-bore carb pad on Edelbrock intakes

E112732



## Carburetor Adapter/Spacer Kits

Most Trans-Dapt Cast Aluminum Carburetor Adapters are reversible & allow a smooth transition between any intake manifold/carburetor combination. These carb adapters are known to increase gas mileage & improve your engine's performance. All Trans-Dapt Cast Aluminum Carburetor Adapters come with the necessary gaskets & mounting hardware.

1" Holley/AFB 4-bbl Carb Spacer With PCV Open Plenum	T372103
Carb Adapter Holley 2V to Small 2-bbl	T372040
1" Quadrajet Carb Spacer Open Plenum	T372109
Carb Adapter 2V Carburetor to 4V Base	T372065
Carb Adapter Universal 4V	T372090

Not sure what you need? Just Ask!



We carry a wide arrange of **Carburetor Spacers, Adapters, Accessories, Gaskets, & Hardware!**

# UNIVERSAL CARBURETOR CHOKE CABLES



## Choke Cable with Polished Knob

Designed for use with Edelbrock Dual-Quad manifolds. This linkage kit provides smooth throttle activation using high-quality aluminum, stainless steel & brass parts with spherical rod ends.

E118013



## Choke Cable

Cable assembly is composed of a sturdy solid steel inner wire with a plated steel outer spring shroud. Cable is 72" long & can be shortened with simple hand tools. Easily installed, it requires a 3/8" diameter mounting hole.

G122078



## Choke Control Cable (Manual)

Can also be used on all Holley manual choke carburetors (like the double pumpers) or any other manual choke carburetor.

H1945228



*GM Transmission Cable Adapter*

*(For use with 2004R, 700R4, 4L60 transmissions)*

E118026



## Throttle Cables & Kickdown Kits

Designed with a specially extruded liner for extended life of the cable - **not to be confused with ordinary braided lines**. Cables are equipped with aluminum fittings & aluminum ferrules to eliminate fraying.

Universal Throttle Cable 24"	TC1000U
Hi-Tech Throttle Cable 24"	TC1000HT
Hi-Tech Throttle Cable 24" (Black)	XTC1000HT
Universal Throttle Cable 36"	TC1000U36
Universal Throttle Cable 36" (Black)	XTC-1000HT36
Hi-Tech Throttle Cable 48"	TC1000HT48
LS1/350 Ramjet Throttle Cable 36"	TC1000LS1U
LS1/350 Ramjet Throttle Cable 36" (Black)	XTC1000LS1

**Transmission kickdown cable kits** are a custom "U-Cut-to-Fit" design that will work in virtually any application. They feature a braided stainless steel housing & specially extruded liner that helps extend the life of the cable for years of reliable service.

Powerglide Hi-Tech Kickdown Kit	KD-20PGHT
TH-400 Electric Hi-Tech Kickdown Kit	KD-2400HT
Polished TH-350 Hi-Tech Kickdown Kit	KDP-2350HT
Polished 200-4R Hi-Tech Kickdown Kit	KDP-2200RHT
Black Hi-Tech GM 4L60 Kickdown Kit	XKD-24L60HT
Black Hi-Tech GM 700-R4 Kickdown Kit	XKD-2700HT
Ford AOD Hi-Tech Kickdown Kit	KD-2AODHT
Ford AOD Universal Kickdown Kit	KD-2AODU
Black Hi-Tech Chrysler 727 Kickdown Kit	XKD-2727HT

"U-Cut-to-Fit" outer housing is available in **24" or 36"** lengths with a "U-Cut-to-Fit" stainless inner wire.

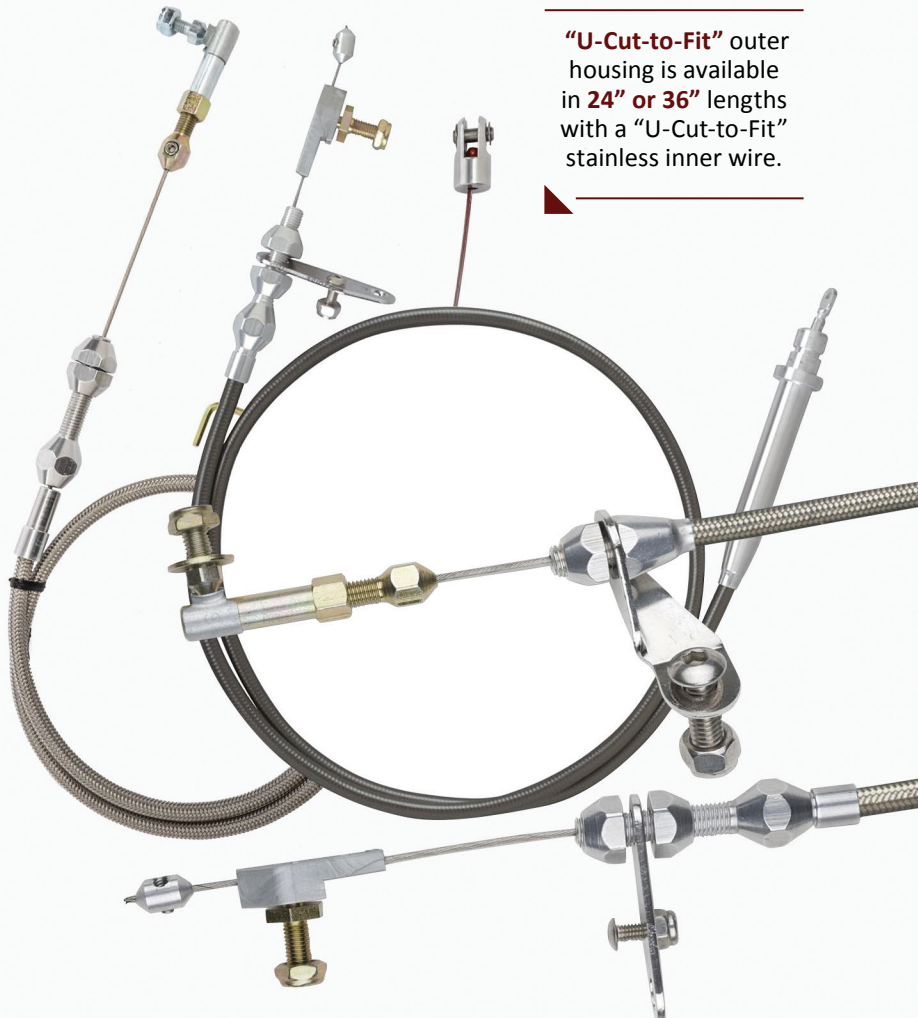





# INTAKE MANIFOLDS



## Performer Series / RPM Series / Air-Gap Series

Patented Dual-plane, low-rise design with a 180° firing order greatly improves torque over a wide rpm range for excellent throttle response from off-idle through 5500rpm.

The **Air-Gap design** features an open air space that separates the runners from the hot engine oil for a cooler, denser charge for more power.

Their larger plenums & runners match high-lift cams, free flowing exhausts & other modifications of a high-output engine.

All-New **RPM Air-Gap** dual-quads are the latest design, featuring an open air space that separates the runners from the hot engine oil for a cooler, denser charge for more power.

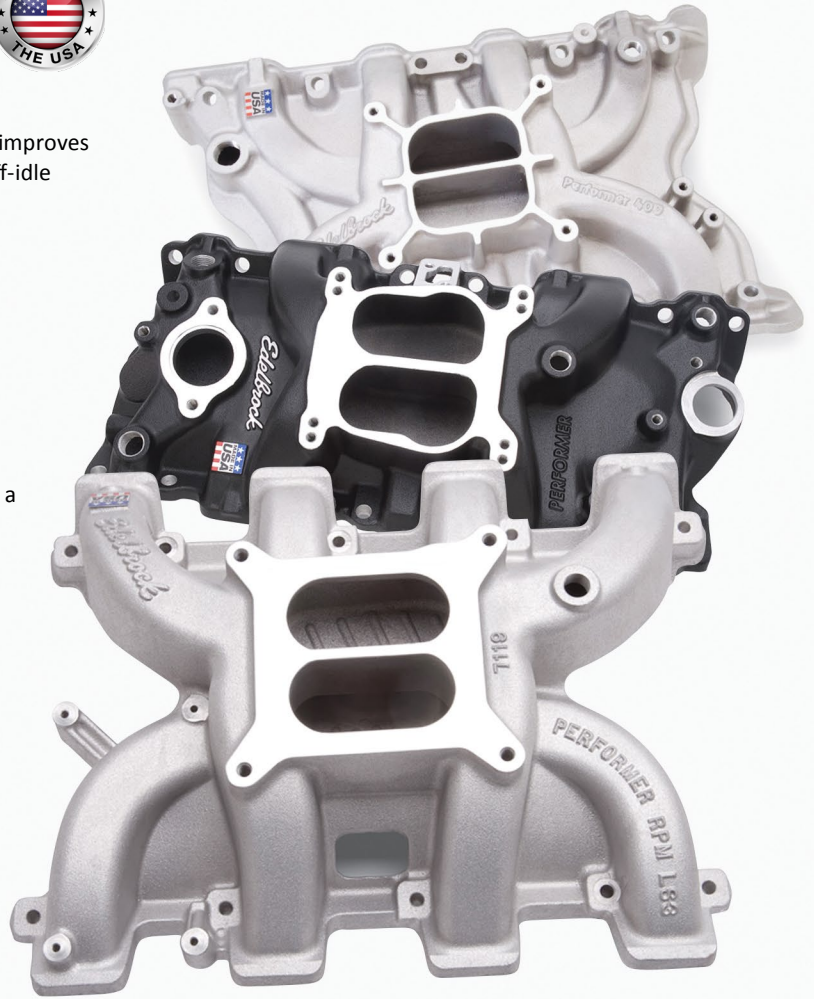

### CHEVY

LS1/LS2 Manifold Only (non-EGR)	E1171187
LS3 Intake Manifold	E1171197
262-400 SBC (non-EGR)	E112101
262-400 SBC (non-EGR) RPM	E117101
262-400 SBC (non-EGR) Black	E112104
262-400 SBC Vortec (non-EGR)	E112116
262-400 SBC Vortec (non-EGR) RPM	E117116
262-400 SBC Vortec (non-EGR) RPM Air_Gap	E117516
262-400 SBC EPS (non-EGR) EnduraShine	E1127014
262-400 SBC (EGR)	E113704
262-400 SBC (non-EGR) RPM Air-Gap	E117501
396-502 BBC 2-O (non-EGR)	E112161
396-502 BBC 2-O (non-EGR) RPM Air-Gap	E117561
396-502 BBC 2-R (non-EGR) RPM Air-Gap	E117562
90° V6 (non-EGR)	E112111
90° V6 Vortec (non-EGR)	E112114

### FORD

289 Performer (non-EGR)	E112121
302 Carbureted (non-EGR)	E112921
302 (non-EGR) Black	E1171213
302 (non-EGR) Air-Gap	E117521
351W (non-EGR) Air-Gap	E117581
390 (non-EGR)	E112105
400 (non-EGR)	E112171
351-2V Cleveland (non-EGR)	E112750
351C (non-EGR) Air-Gap	E117564
460 (non-EGR)	E112166

## Super Victor Series / Victor Jr. Series

Single-plane, high-rise intakes designed for maximum race-winning power at higher engine speeds. Engineered in conjunction with leading engine builders & racers from all forms of competition, these intakes incorporate modern design with the latest racing technology. Victor manifolds are available for single or multiple-carburetor set-ups.

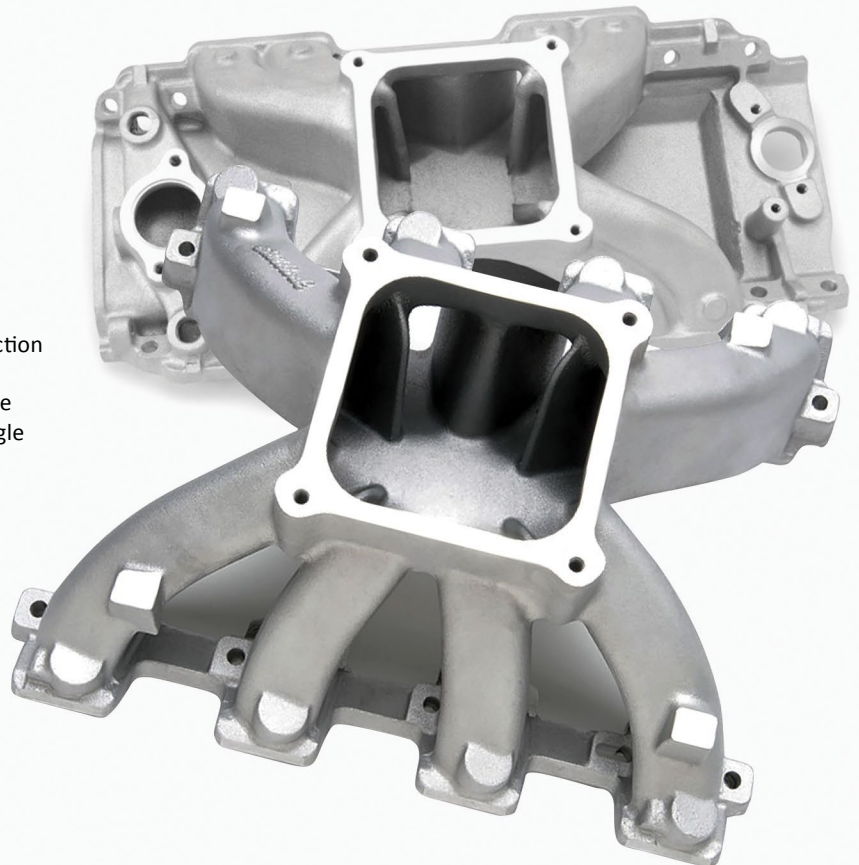

### CHEVY

LS1/LS2 EFI Manifold	E1128095
LS1/LS2 Competition EFI Intake Manifold Only	E1129085
LS1/LS2 Manifold (for use with carburetor)	E118097
LS3 Carbureted Manifold for 4500 Series Carbs	E112821
LS3 Carbureted Manifold for 4150 Series Carbs	E112826
396-502 BBC Standard-Deck (9.8")	E112896
LS Gen IV Carbureted Manifold for L92 Heads	E1128457
EFI Manifold for L92 Heads	E1128455
262-400 SBC	E112975
396-502 BBC 454-R	E112907

### FORD

351W (9.5" deck)	E112924
351W (9.5" deck)	E112981



EFI

## Intake Manifolds

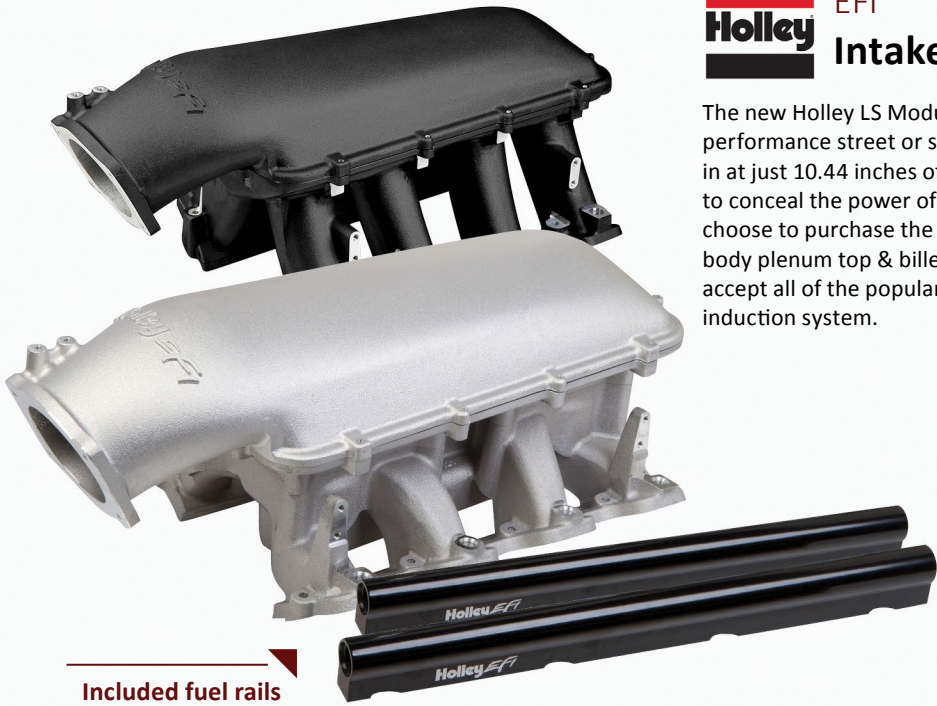

Included fuel rails are machined for -8 AN O-ring fittings

The new Holley LS Modular Mid-Rise Intake manifold is an excellent choice for performance street or strip applications with limited hood clearance measuring in at just 10.44 inches of overall height. The modular base design allows you to conceal the power of your LS powered project under the hood whether you choose to purchase the complete intake kit with 92mm or 105mm EFI throttle body plenum top & billet fuel rails or use the optional upper plenum adapter to accept all of the popular Holley Hi-Ram plenum tops as a foundation for a custom induction system.

**1500 - 6500 RPM**  
Operating Range

### CHEVY

Mid-Rise Intake (GM LS1/LS2/LS6)	H19300126
Mid-Rise Intake (GM LS1/LS2/LS6) <i>Black</i>	H19300126BK
EFI Hi-Ram Intake (GM LS Throttle Body)	H19300117
EFI Hi-Ram Intake (GM LS Throttle Body) <i>Black</i>	H19300117BK
Cathedral Port EFI (LS1/LS2/LS6)	H19300123
Cathedral Port EFI (LS1/LS2/LS6) <i>Black</i>	H19300123BK
GM LS Gen III /IV (LS3/L92 style rectangular ports)	H19300135
LS1/LS2/LS6 Cathedral Port EFI	H19300122
EFI 2x4 Mid Rise Dual Plane Intake Manifold	H19300134
- (LS3/L92 style rectangular ports)	



Dual Plane

## Intake Manifolds

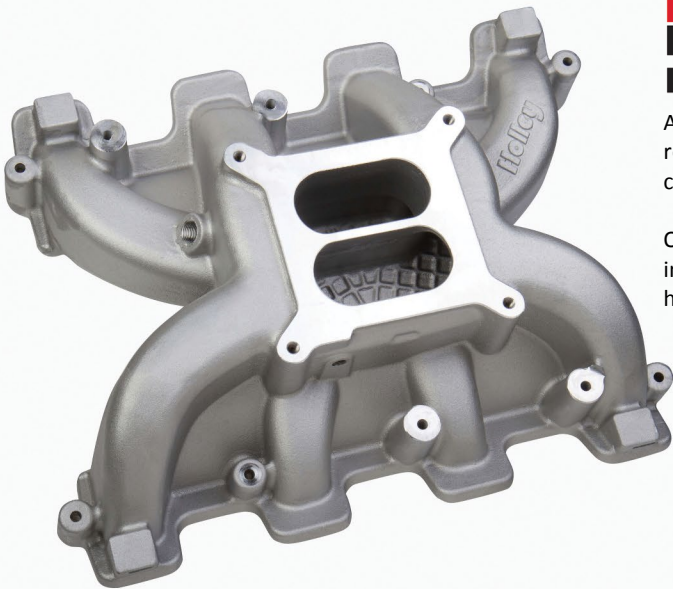

A dual plane design makes this manifold perfect for low-end torque while still reaching up to 6500 RPM. The cast aluminum construction is light & efficient with consistent wall thicknesses & improved casting quality.

O-ring cylinder head mounting flange gaskets provide an OE-style seal that makes installation a snap! Minimum carb flange height means the manifold clears the hood with little to no modification.

LS Gen III /IV  
(LS3/L92 style rectangular ports) H19300129

LS Gen III /IV  
(LS1/LS2/LS6 style cathedral ports) H19300130



Atomic AirForce

## LS & LT Series Intake Manifolds



The polymer molded two piece intake features unique bell formed runner openings that improve the air distribution into each cylinder. The intake is a true bolt-on performance boost & is available for LT1 engines as well as most LS-series engines.

- 103mm throttle bore allows aftermarket throttle bodies.
- Polymer molded material resists heat build-up.
- Improved air/fuel ratio distribution through all operating ranges.
- Direct flow path design promotes maximum airflow.
- Two piece intake design allows you to port runners.

LS1/2/6 - M463701    LS7 - M463701    LT1 - M463700





## Sniper EFI Fuel Injection

Perfect for street rods, muscle cars, off road trucks or nearly any carbureted vehicle. Put an end to cold start issues, hesitations, vapor lock, & flooding.

- Bolt on carburetor replacement (single & dual carb manifolds)
- Throttle body mounted ECU
- Supports up to 650hp (4 inj. ver.)
- 4 wire vehicle connection (Batt. +, Batt. -, Switched Ign. & RPM)
- Integrated fuel pressure regulator, ign. timing control & coil driver
- Color touch screen for setup & gauge views
- Calibration Wizard - NO laptop required - Self-tuning ECU
- Included Wideband Oxygen Sensor - Real-time Fuel Map Learning!

Master kits include: fuel system fuel pump, filters, feed hose & all fittings including fuel tank return line bulkhead fitting.



Shiny Finish

Black Finish

Also available in GOLD!



## "Go EFI" Self Tuning Fuel Injection Systems

FiTech's Go EFI-4 600 HP Throttle Body System is suitable for 250 HP through 600 HP engines, making this basic system designed for everyday driving, weekend street machines or bracket racing applications.

Bright Aluminum - FIT30001 | Matte Black - FIT30002

"Go Street" 400HP System - FIT30003

600HP Power Adder System - FIT30004

The Go EFI Power Adder 600HP Kit is for the enthusiast that demands more from his system or is planning a future upgrade! This system is capable of 25 lbs of Boost right out of the box & can be used in a blow thru turbo or blower application or on a single roots style supercharger. You can also run a single stage of Wet Nitrous & control your A/F as well as Ignition timing.

Meanstreet EFI 800HP System - FIT30008

FiTech's MeanStreet EFI Systems are designed for engines that produce up to 800 HP. The 8-injector throttle bodies are built for solid ignition systems. FiTech's self-contained throttle bodies will fit any 4-bbl intake manifold & is considered the most full-featured unit of this type.

1200HP Power Adder PLUS System - FIT30012

The Go EFI 8 1200 HP (Power Adder Plus) is the Ultimate system for the serious power builder. This system features 8 High Flow injectors & is capable of fueling 1200 HP! The Go EFI 8 1200HP is our TOP OF THE LINE system & comes with all of the Data-logging, & Pro-tuning software as standard features. PLUS The Annular Discharge design is increased to 20 jet streams to handle the monster flow of this unit!

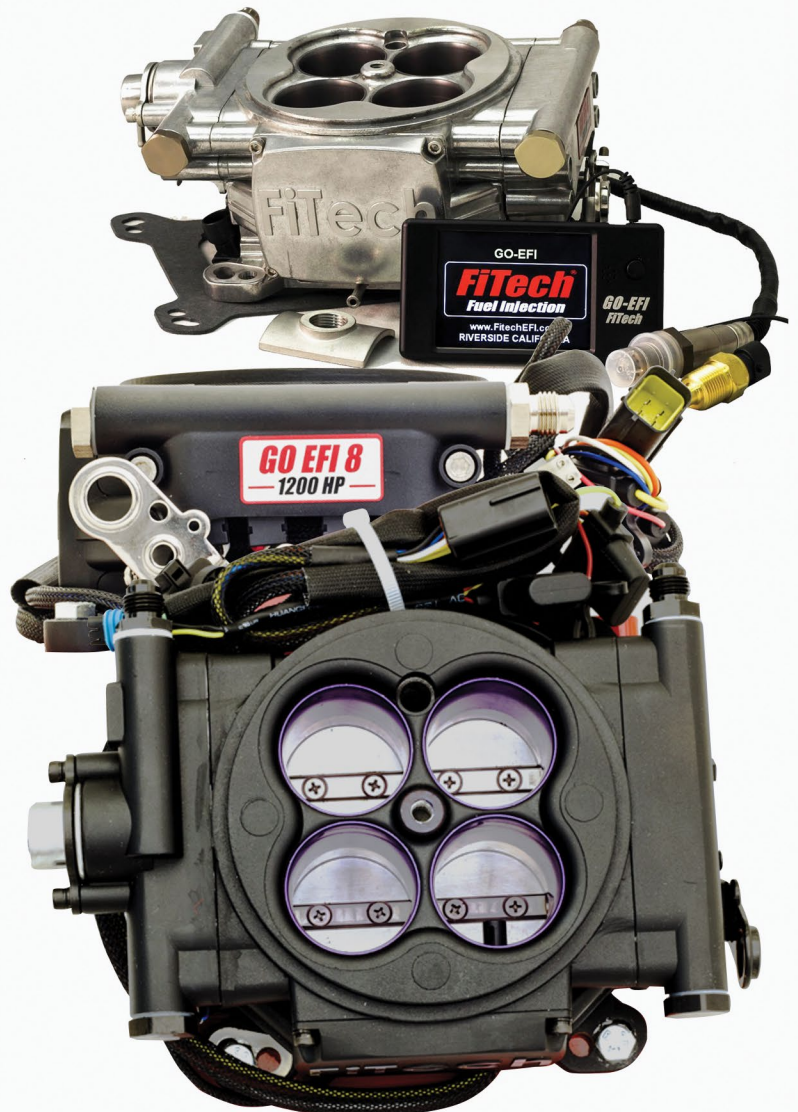



## Pro Flow Air Cleaners

Edelbrock triple chrome-plated round air cleaners work with all popular 5-1/8" diameter carburetors.

10" Round w/ 3" Paper Element **E111208**  
3-5/16" Overall Height

14" Round w/ 3" Paper Element **E111221**;  
3/8" Deeper Flange for all Edelbrock Carbs (3-7/16")

1000 Series Reusable Air Cleaner **E111002**  
for 4-bbl. Carbs with 5-1/8" Air Horn

High-Flow 14" Round **E1143662**  
Color-matched breathable lid & 3" tall element (black filter & trim).



## Licensed Chevrolet & Ford Air Cleaners

Chevy Classic Style Air Cleaner  
Chrome; Recessed Red/Black Chevrolet & Bowtie Emblems  
No Center Nut - **P75141906**  
Chrome; Embossed Chevrolet Lettering Design Bowtie Center  
Nut Included; Stamped Steel; 14" Dia. - **P75141302**

Chevy Super-Light Racing Aluminum Air Cleaner Kit  
Black Aluminum; Deep-Recessed Base; No Logos **P75141690**  
Clear Anodized; Deep-Recessed Base; No Logos **P75141691**

Classic Ford Racing Air Cleaner w/ Center Nut  
Chrome; Ford Emblem & Black Mustang Lettering **P75302361**  
Chrome; Embossed Ford Racing Emblem & Black Lettering  
**P75302351**  
Chrome; Ford Emblem & Black Cobra Lettering **P75302371**

Slant-Edge Air Cleaners  
Black Crinkle; Raised/Milled Emblems; 13" Diameter **P75302380**  
Ford Blue; Raised/Milled Emblems; 13" Diameter **P75302381**  
Gray Crinkle; Raised/Milled Emblems; 13" Diameter -  
**P75302382**



## Round Air Filter Assembly

Provides more air flow to the engine.  
Designed to increase horsepower  
Includes Washable & reusable K&N air filter

▲ **X-Stream Top Assembly - K33663040**

*X-Stream Top Filters* **Black - K33661401**

**Red - K33661401XR** **Blue - K33661401XB**





## Easy-Flow Air Cleaners

Mr. Gasket's Easy-Flow air cleaners feature a gleaming, chrome finished top cover with a plated steel base that encloses a high cfm, replaceable, flame retardant paper element.

*Includes Stud & Wing Nut*

### **9" Round 2-3/4" Tall - G121487**

Air Cleaner, 14 in Diameter, 3 in Height, Chrome, Kit

### **14" Round 2-1/4" Tall - G121480**

Fits 5-1/8" Diameter Carb. Neck- Chrome

### **14" Round 3" Tall - G129790**

Fits 5-1/8" Diameter Carb. Neck- Chrome



## Air Cleaner Set

Round Muscle Car Style Top Air Cleaner Set

- 14" x 3"
- Fits Single Quad Carburetors
- With Paper Element
- Chrome Plated Steel Top
- Flat Chrome Plated Steel Base

### **14" Round 3" Tall - RPCR8000**



## Single or Dual Quad Aluminum Street Hood Scoop

These Dual Quad Hood Scoops have an adjustable centerline that measures 7.75 to 9.25 inches with either red or black flaps. Each street hood scoop includes a 6.375 inch x 2.5 inch element, mounting hardware & adapter plates for either dual or single application.

RPC5239

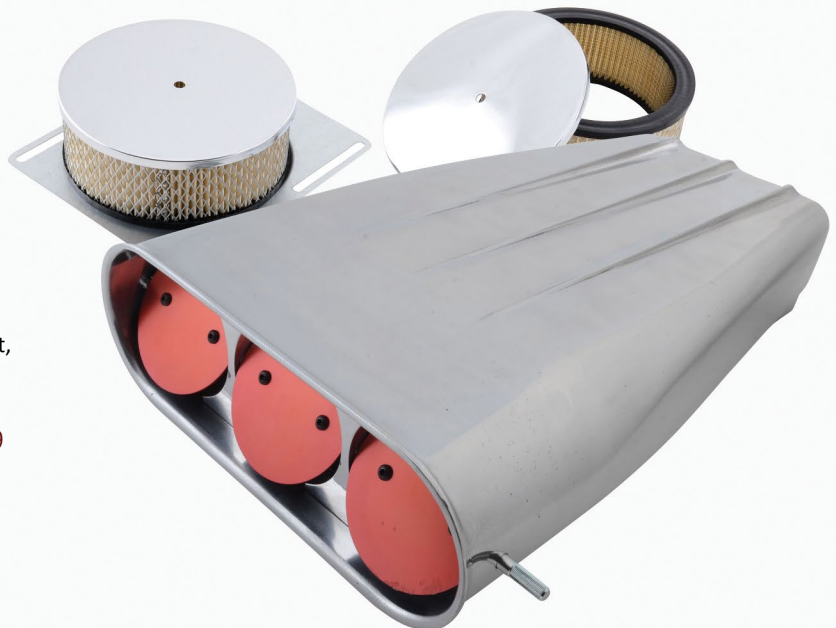





## Clamp-On Universal Air Filters

K&N's Universal Air Filters are designed & manufactured for a wide variety of applications including racing vehicles, radio-controlled cars, generators, snowmobiles, tractors, & other applications. Regardless of the angle or offset diameter of the air intake, there is probably a K&N Universal air filter for your equipment. K&N universal air filters are washable & reusable.



### Available Filter Configurations

**Flange Diameters** - From 2.5in. - 6in.

**Filter Lengths** - From 5in. - 9in.

Offered in a variety of configurations as seen below!

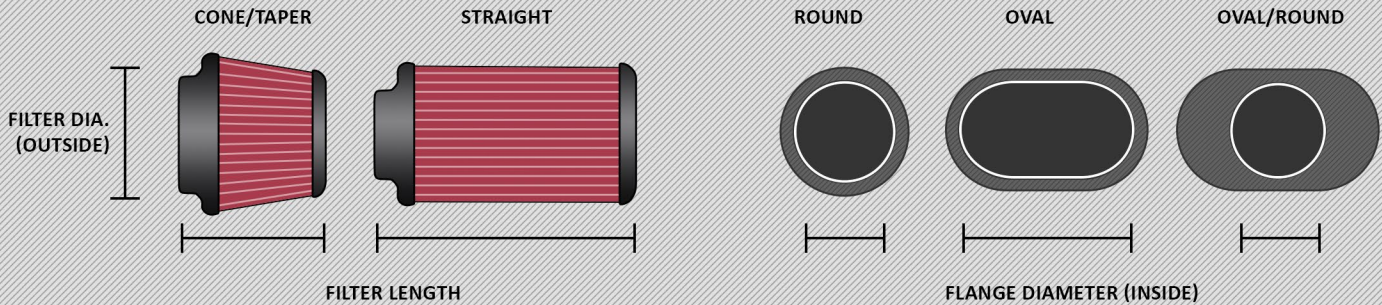

## Power Plus Series Throttle Bodies

These BBK Power+Plus Throttle Bodies Are Direct Replacement Units & Increase Airflow For Improved Performance Over Stock.

Available For Many Late Model American Muscle Cars & Trucks, Including Mustang, Charger, Challenger, Chrysler 300, Magnum, Raptor, F Series, Jeep, Viper, Camaro, Corvette, & many more.



**NO TUNE REQUIRED!**



**All BBK Power Plus Throttle Bodies Are Direct Replacement Bolt On Units**

### DODGE

2013-17 Dodge Hemi 5.7L, 6.4L 85mm	<b>B451842</b>
2013-17 Dodge Hemi 5.7L, 6.4L 90mm	<b>B451843</b>
2003-12 Dodge Hemi 5.7L, 6.1L, 6.4L 85mm	<b>B451781</b>
2003-12 Dodge Hemi 5.7L, 6.1L, 6.4L 90mm	<b>B451782</b>
2004-06 Dodge Ram SRT-10 Truck 67mm	<b>B451776</b>
2003-2007 Dodge Viper Twin 67mm	<b>B451767</b>
Cable Driven Hemi 5.7/6.1/6.4L 80mm	<b>B451791</b>
Cable Driven Hemi 5.7/6.1/6.4L 80mm	<b>B451792</b>

### CHEVY

1985-88 GM Tuned Port 305 52mm	<b>B451534</b>
1985-88 GM Tuned Port 305 58mm	<b>B451536</b>
1989-92 GM Tuned Port 350 52mm	<b>B451537</b>
1989-92 GM Tuned Port 350 58mm	<b>B451539</b>
1992-93 LT-1 5.7L 52mm	<b>B451540</b>
1992-93 LT-1 5.7L 58mm	<b>B451542</b>
1994-97 LT-1 5.7L 52mm	<b>B451543</b>
1994-97 LT-1 5.7L 58mm	<b>B451544</b>
1998-03 80mm Throttle Body - LS1 Camaro/Firebird GTO	<b>B451709</b>
1998-03 85mm Throttle Body - LS1 Camaro/Firebird GTO	<b>B4517090</b>
1997-04 LS1 Corvette 80mm	<b>B451708</b>
1996-99 GM Vortec 305 & 350 80mm	<b>B451756</b>
2003-06 GM 4.8L 5.3L 6.0L & H2 80mm	<b>B451757</b>
10-15 Chevrolet LS3/L99 6.2L 95mm	<b>B451789</b>
10-15 Chevrolet LS3/L99 6.2L 102mm (w/ 1/4" Adapter Plate)	<b>B451790</b>

### FORD

2015-Up 2.3L Ecoboost 65mm	<b>B451594</b>
2015-17 85mm Mustang GT 5.0L	<b>B451806</b>
2015-17 90mm Mustang GT 5.0L	<b>B451807</b>
2011-14 Mustang GT, Boss 302, 11-14 F Series Truck 5.0L	<b>B451821</b>
2011-14 Mustang GT, Boss 302, 5.0L	<b>B4518210</b>
05-10 Mustang GT 4.6L Twin 62mm	<b>B451763</b>
07-14 Shelby GT500 Twin 65mm	<b>B451764</b>
96-04 4.6 2V Mustang 70mm	<b>B451700</b>
96-04 4.6 2V Mustang 75mm	<b>B451701</b>
94-95 Mustang GT 75mm	<b>B451524</b>



# K&N COLD AIR INTAKES

K&N air intake products add horsepower, torque & acceleration to your vehicle. If you are looking to improve performance, K&N air intakes & cold air induction systems are easy to install & come with a million mile limited warranty. K&N air intake systems are available for cars, trucks, motorcycles, ATV's & RV's.

## CHEVY (GM)

1996-05 SUV 4.3L/262 V6	K3330172
1999-05 Impala, Monte Carlo, Grand Prix 3.4L/207 V6	K333045
1994-96 SBC (LT-based) 5.7L/350 V8	K333011
1999-07 SBC Gen III/IV (LS-based)	K333023
2009-14 SBC Gen III/IV (LS-based) 4.8, 5.3, 6.0L V8	K333070
2010-15 Camaro SBC Gen III/IV (LS-based) 6.2/376 V8	K334519TP
2014-17 Silverado/Sierra 1500 4.3L/262 V6	K333085
2014-17 Pickup, SUV SBC Gen V 6.2L/376 V8	K333082
2011-2013 Silverado/Sierra 2500 6.0L/364	K333076KTK

## DODGE/CHRYSLER

2003-06 Viper 8.3L/505 V10	K331536
1995-98 Viper 8.0/488 V10	K331508
Magnum, Challenger, Charger 5.7L/6.1L, Hemi, V8	K331542
Chrysler 300 5.7L/6.1L, Hemi, V8	K331542
2003-08 RAM 1500/2500/3500 5.7L/345	K331533
2011-18 Hemi Gen III 5.7L/345	K331114
2009-17 Ram 1500 5.7L/345	K331561
2012-17 Jeep Wrangler JK 3.6L, V6	K331566

## FORD

1996-04 Mustang GT 4.6L/281 Modular V8	K3325193
1996-01 Mustang SVT Cobra 4.6L/281 Modular V8	K3325232
2004-08 SUV, Pickup, 5.4L/330 Modular V8	K332556
2005-06 Mustang GT 4.6L/281 Modular V8	K332565
2011-14 Mustang GT 5.0L/302 Modular V8	K332578

## NISSAN/INFINITI

2003-2006 350Z 3.5L V6	K337070TP
2008-17 370Z, G37 3.7L V6	K337078TS



## Authorized Dealer

57 Series Fuel Injection Performance Kits (FIPK)  
 77 Series High Performance Air Intake Systems  
 63 Series AirCharger® High Performance Air Intakes  
 69 Series Typhoon® Air Intake Systems  
 Blackhawk Induction™ Air Intake Systems



Not Sure? Ask us about your make/model.



# BBK COLD AIR INTAKES

BBK Performance Offers Power Plus Cold Air induction Systems For most popular Chevy, GM, Dodge & Ford Direct Bolt On With No Tune Required, Each Kit Offers Up To 20+ Horsepower Right Out Of The Box & Install In Minutes With Simple Hand Tools.

*Chrome & Blackout Powdercoat Finishes Available For Most Applications*



## CHEVY

2010-15 SBC Gen III/IV (LS-based)	B451738
-----------------------------------	---------

## FORD

1986-93 Mustang GT 5.0L/302 V8	B4515575
1996-04 Mustang GT 4.6L/281 Modular V8	B451718
2005-10 Mustang 4.0L/245 V6	B451737

## MOROSO Air/Oil Separators

Plumbed into a vehicle's breather/PCV system to capture excess crankcase vapors & the residual oil mist from re-entering the intake track. There are versions available for factory configurations, vacuum pumps, & universal installations.

### Air-Oil Separator Kits, Large Body

The original size, 43% more capacity than the Small Body Version. Features a bottom drain with elbow that makes draining the collected oil virtually mess-free. Polished body can be chromed, painted, or powder coated for a custom look.

### Air-Oil Separator Kits, Small Body

Smaller size fits in more applications & some customers prefer the smaller size body. Two piece body unscrews for draining. Available with a polished or black anodized finish.



Cooling System

## Expansion Tank

These expansion tanks are perfect for cars with low-mount radiators to provide a convenient filling location & to bleed off unwanted air. Comes with straight barbed fitting, 1/4" NPT petcock, 1/4" NPT plug & 1/4" NPT 90 degree fitting.



Radiator & Automatic Transmission

## Overflow Tanks

Moroso radiator overflow tanks have a capacity of one (1) full quart that can be used in NHRA & IHRA competition, & include hose fittings & a drain!

Pressurized fluid is captured in the expansion tank & will drain back into the transmission as the transmission cools. Excess fluid may also be drained between rounds, by using the ball valve.



## Breather Tank

Great for low vacuum venting & may be modified for additional fitting for dual vent hoses.



## Breather Kit

Breathers push into valve covers & allow clean air to get into the crankcase.



Chevy/ Ford Licensed Push In

## Air Breather Caps

These popular push-in filter air breathers, with the raised Bowtie Emblem stamped prominently in the top, are offered with the heat-shield hood & without.



Clamp On/ Push-In

## Breather/Filter Caps

- Foam WEB Clamp-On - RPCR9307
- Aluminum Push-In PCV Breather - RPCR6000 & RPCR6001
- Nostalgic Push-In Aluminum Breather - RPCR6505



Vent Air

## Filter/ Breather

Flange Diameter  
3/8" | 1/2" | 3/4" | 1" | 1-1/4" | 1-1/2"  
Top/Base Material

- Chrome/Chrome
- Chrome/Rubber
- Rubber/Chrome
- Carbon Fiber



Breathers/Oil

## Filter Caps

These breathers keep your crankcase properly vented & add a little style under the hood. Mr. Gasket valve cover breathers are available in push-on or push-in styles. Chrome or Black Available.





# MSD Pro Billet Distributors

The housing is machined from a billet of 6061-T6 aluminum on a state-of-the-art CNC machine producing exact tolerances. For high rpm stability, a .500" steel shaft is supported by a sealed ball bearing & a long sintered bushing. This shaft also receives a QPQ coating for friction reduction & resistance to corrosion.

A precision machined reluctor is attached to the shaft which triggers the magnetic pick-up mounted in the housing. This high output magnetic pick-up is the most accurate way to trigger your ignition. Plus, with no moving parts to wear or adjust, the pick-up is maintenance free! Just above the pick-up is MSD's adjustable mechanical advance assembly.

## ASK ABOUT OUR COMPLETE IGNITION KITS

### CHEVY

SBC/BBC	M468551
SBC/BBC (Black)	M468555
SBC/BBC w/ Locked Out Timing	M4685501
SBC/BBC w/ Slip Collar	M4685561
SBC/BBC HEI	M468365
SBC/BBC Small Diameter (Black)	M46 85703
SBC/BBC Small Diameter	M46 8570
Corvette Tach Drive w/ Vacuum Advance	M46 8572
SBC/BBC Flat Top	M46 84891
194, 230, 250, 292, L6 (6 Cylinder)	M46 8515
SBC/BBC Locked-Out Timing/Bronze Gear (Black)	M46 85505
SBC/BBC Vacuum Advance	M46 8361
SBC/BBC Vacuum Advance (Black)	M46 83613
90 Degree V6 Even-Fire 4.3L	M46 8597

### CHRYSLER

273, 318, 340, 360 Small-Block	M46 8534
426, 440 Big-Block (Black)	M46 85463

### AMC

AMC/JEEP 232-258 4.0L	M46 8516
AMC V8 290, 304, 343, 360, 390, 401	M46 8519

### BUICK

Buick V8 400-455	M46 8517
Buick V8 215-350	M46 8548

### PONTIAC

Pontiac V8 350-455	M46 8563
--------------------	----------

### VOLKSWAGEN

VW Type 1 (air cooled)	M46 8485
------------------------	----------

### FORD

Ford V8 302	M468582
Ford V8 302 Small Diameter	M468579
Ford 351W	M468584
Ford 351W Steel Gear	M4685840
Ford 351W (Black)	M4685783
Ford 351C-460 Street	M468477
Ford 351W Small Diameter	M468578
Ford V8 351C-460	M468580
Ford V8 351C-460 Steel Gear	M4685801
Ford 351W Edelbrock Victor Jr.	M4685808
332, 352, 360, 390, 406, 410, 427, 428 FE ENGINES	M468594
Ford 289/302	M468598
Ford 5.0L (Black)	M4684563
Ford 351C-460 (Black)	M4685773
Ford 5.0L	M468456
Ford TFI EFI 351W w/ Module	M468452
Ford 351C-460	M468577
Ford 289/302 Street	M468479
Ford 289/302 Street w/ Steel Gear	M4684791
Ford 289/302 Street	M468497



## EQUIPPED WITH ONBOARD IGNITION MODULES

## MSD Ready To Run Distributors

This distributor is Ready-to-Run meaning that you simply need to install it in the engine & connect three wires to fire up the engine. No external ignition controls are required with this distributor because it has a powerful module built into the housing.

✓ Built-In Rev Limiter

✓ Built-In Ignition Module

### CHEVY

348/409	M468393
SBC/BBC Internal Module	M468360
SBC/BBC Internal Module (Black)	M4685603
SBC/BBC Digital E-Curve	M468394

### FORD

332, 352, 360, 390, 406, 410, 427, 428 FE 289/302	M468595
351C-460 (Black)	M468352
351C-460 Steel Gear	M4683503
351C-460	M4683501
351W Steel Gear	M468350
289/302 (Black)	M468350
289/302 Steel Gear	M4683541
4.8/292, 5.1L/312, 3.9/239	M468354
	M4683523
	M4683521

### CHRYSLER

318-360	M468388
426-440 (Black)	M4683873
426-440	M468387
363-400	M468386

### BUICK

322, 364, 401, 425 Nailhead	M468524
-----------------------------	---------

### PONTIAC

326, 350, 389, 400, 421, 428, 455	M468528
-----------------------------------	---------

### OLDSMOBILE

260, 307, 330, 350, 400, 403, 425, 455	M468529
--	---------



# MSD Crank Trigger Distributors

MSD Ignition Crank Trigger distributors are designed for racing engines that use a crankshaft triggered ignition. Their low profile lets them fit in tight quarters & still accurately deliver the sparks. Built around a CNC-machined billet aluminum housing.

CHEVY	
SBC/BBC	M4684697
SBC/BBC Crab Cap	M468489
BBC Tall Block Chevy V8	M468558
FORD	
351W	M468378

## Crank Trigger Kits

CHEVY	
SBC 6.25" Balancer	M468600
SBC 6.25" Balancer (Black)	M4686003
SBC 7" Balancer	M468610
SBC 7" Balancer (Black)	M468610
SBC 8" Balancer	M468615
SBC 8" Balancer (Black)	M4676153
BBC	M468620
BBC (Black)	M4686203
FORD	
Ford Small Block	M468640
Ford Big Block	M468644
PONTIAC	
Pontiac V8 287-455, 7"	M468650
CHRYSLER	
Chrysler Small Block	M468633
Chrysler Big Block	M468636



*Crank Triggers provide extremely accurate timing circumventing flawed timing chain driven designs.*



# MSD Marine Distributors

Marine environments place rigorous demands on every component of the ignition system, especially the distributor. The combination of water spray, salt exposure, full throttle acceleration & harsh vibrations all take their toll. For marine use, the distributor cap is bolted to the aluminum base. There are two flame arrestor holes with brass screens machined into the base of the distributor to prevent ignition of gas fumes that may build up in the engine compartment. A special Weathertight Connector is supplied to provide a positive-lock & water resistant connection.

The Marine Pro-Billet Distributors have been tested by Underwriter's Laboratory & are certified to meet or exceed safety standards for marine ignition systems as set by the U.S. Coast Guard.

CHEVY	
Chevy V8 Ready-to-Run	M4683606
Chevy V8 Marine Certified	M468560
Chevy V8 Ready-to-Run Black	M4683607







## DISTRIBUTORS

MSD Street Fire is the value line of MSD Ignition. Street Fire components offer a quality-designed alternative to the bargain parts springing up all over. The Street Fire is fit with the same gear used on Pro-Billet models. The metallurgy of this gear has been refined for years to perform through the harshest conditions.

✓ **All New Components**

✓ **Heavy-Duty Distributor Gear**



*Drop-in Stock Replacment Distributors*



### Cap & Rotor Kits

These MSD Street Fire Cap & Rotor kits are designed with brass terminals & a heavy duty rotor for affordable & easy ignition maintenance.



### Canister Coils & Coil Packs

Street Fire Coils mount in place of factory coils & accept OE connectors. Spark energy is increased thanks to improved materials & more efficient winding ratios that were selected by MSD engineers.



### Spark Plug Wires Sets

MSD Street Fire Ignition Wire Sets are made with a low resistance conductor that is wrapped in a durable black sleeve. Black boots cover the terminals to protect the conductor from engine heat & ensure spark delivery. Street Fire wires are spec'd by MSD engineers & are backed by a one year warranty.

#### CHEVY

LS1, LS6, '97-On, Vette, Camaro	M465572
GM Truck, Vortec, '96-'97	M465573
M Truck, 4.8L, 5.3L, 6.0L, '98-'05	M465574
LT1, Camaro '93-'96	M465575
GM Vortec V6, 4.3L '96-'04	M465577

## MSD Cap & Rotor Kits



MSD distributor caps & rotors are designed with performance in mind & molded from high-quality, voltage-insulating material with terminals that resist carbon tracking. Whenever the distributor cap is changed, you should install a new rotor.

## MSD Distributor Gears

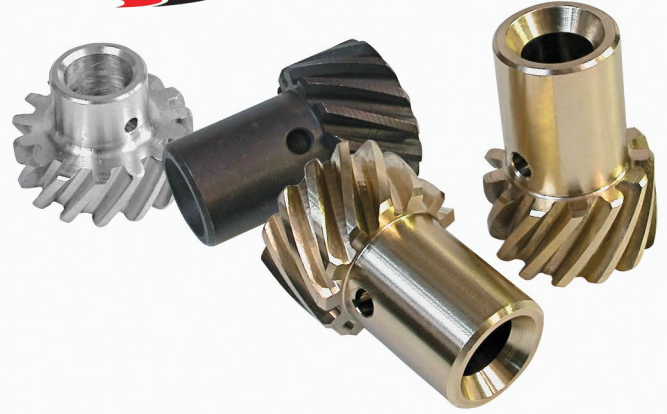

**Iron & Steel Gears** - High grade iron & steel replacement gears for MSD distributors. Burnished for a smooth scuff-free finish & are machined from a proprietary, high density material.

**Bronze Gears** - Machined from quality AMPCO-45 aluminum bronze containing 5% nickel. This special material creates high strength gear teeth that are less prone to wear when used with high volume oil pumps

## MSD Super Conductor Spark Plug Wire Sets

### CHEVY

SBC, Socket Cap	M4631653
SBC, Socket Dist. Cap	M4631659
SBC w/HEI Tower Cap	M4635653
SBC w/HEI Cap	M4635659
SBC for use with HEI Cap	M4635599
SBC - Low Profile Distributor	M4631249
SBC HEI (Black)	M4631353
SBC 350 HEI	M4631359
BBC for HEI Tower Cap (Red; Black)	M4635609; 35603
BBC 454, '74-'76 HEI (Red; Black)	M4631369; 31363
BBC 366-454 Socket (Red; Black)	M4631379; 31373
SBC '82-'83 Camaro/Trans Am	M4631409
SBC Truck 305-350 '85-On (Red; Black)	M4631419; 31413
Chevy Corvette, LT1, V8, '92-'97	M4632179
Corvette, 305, 350 HEI (Red; Black)	M4631769; 31763
Corvette 350 TPI	M4631459
Chevy 366-454 w/HEI Cap	M4635379
BBC, Socket Dist. Cap	M4631609
BBC, '88-on (Red; Black)	M4631809; 31803
BBC '75-on, HEI (Red; Black)	M4631779; 31773
Caprice/Camaro '88-On	M4631839
Caprice/Impala, LT1 5.7/4.3 '94-'96	M4632159
LT1 Camaro '93-'96	M4632149
GM LS1, Vette/Camaro, '97-On (Red; Black)	M4632079; 32073
GM LS1, '97-On, Vette, Camaro (Red; Black)	M4632813; 32819

### FORD

Mustang 5.0L '94-On	M4632209
96-'97 Mustang Cobra, 4.6L	M4632219
Ford 351C-400, Socket	M4631389
Ford 351C-460, w/HEI Cap (Red; Black)	M4635389; 35383
Ford 302, 351W, HEI (Red; Black)	M4631329; 31323

### CHRYSLER

318-360, Socket	M4631309
383-440 HEI for MSD Distributor	M4632739
318-360 HEI, for MSD Distributor	M4632749

### AMC

AMC V8 Engines w/HEI Cap	M4635859
--------------------------	----------

### DODGE

'03-'04 Dodge Neon SRT-4, 2.4L Turbo	M4632689
03-'05 Dodge, 5.7L Hemi (Red; Black)	M4632039; 32033

**Super Conductor Universal 8.5mm Wire Sets** have spark plug terminals & boots installed with the opposite ends open. Distributor cap terminals & boots are included so you can cut wires to desired lengths, then use the included Mini-Stripper-Crimper to install terminals. 2-in-1 wire sets include terminals & boots for both socket & HEI-style distributor caps.

V8 Multi-Angle Plug (Black) Socket/HEI	M4631193
V8 Multi-Angle (Red) Socket/HEI	M4631199
V8 90° Plug/ 90° Plug (Red); (Black)	M4631229; 31223







## Digital 6A Ignition Control

The **Digital 6A** is a microprocessor controlled, capacitive discharge ignition that multi sparks up to 3,000 RPM providing easy starts, a clean, smooth idle & quick throttle response by optimizing your engines efficiency. Above 3,000 RPM, a single spark stays lit for up to 20° of crankshaft rotation ensuring a complete burn of the air / fuel mixture in every cylinder.

Inside the **Digital 6A** you'll find a microprocessor that monitors & controls every firing & rev limit. The circuits are updated with efficient components that help the ignition produce more power while drawing less current! In fact, the Digital 6A delivers over 530 volts to the coil with up to 135mj of spark energy for every firing! Increased output combined with MSD's proven multiple spark series is a win-win situation!



## LS Ignition Control Box

The one box you need to control your LS ignition. Now easier to use & available in red or black.



## Digital 6AL-2 Ignition Control

New housing, new digital controls & more power in a sleek package. Inside the new cast aluminum housing you'll find an advanced micro-controller that manages the built-in two step rev-limiter.



## Power Grid System Controller

**Power Grid System Controller** - This is the "brain" of the Power Grid System - designed for use with the **PN 7720** ignition controller, but compatible with many of MSD's other popular ignition boxes. Requires a Windows-based laptop for configuration.

The **Power Grid Ignition Control** has been specially designed to mount to the Power Grid System Controller box, **PN 7730 (Red); 77303 (Black)**. This Ignition output only controller packs higher output than the current programmable units!





## MSD Digital 6 & 7 Plus Ignition Control

The **MSD Digital-6 Plus** Ignition Control combines terrific power, digital accuracy & great accessories making it ideal for street/strip applications. Every spark of the Digital-6 Plus Ignition is packed with 135 millijoules of spark energy & 535 primary volts.

The **Programmable Digital-7 Plus** includes all of the standard programmable features such as Individual Cylinder Management, Step Retards, Rev Limits, Shift Points all while increasing the spark energy to 190 millijoules!



## MSD Blaster 2, 3, & High Vibration Ignition Coils

**Blaster 2 Coils** are designed for improved spark output! Special 100:1 windings are used to provide maximum build-up of voltage! These windings are held secure & kept cool in an oil filled metal canister.

The **Blaster 3 Coil** features an extra tall tower design to improve the coil wire attachment & spark isolation. Supplied with a 90° terminal & boot.

The sturdy metal housing of the **High Vibration Coil** is completely potted with a premium grade epoxy to completely encase the coil's primary & secondary windings.

## MSD Blaster SS Ignition Coils



Don't let the compact size of the **Blaster SS Coil** fool you, because it is packed with performance! The efficient E-core windings are designed to produce high amounts of current without sacrificing the voltage output. In fact, when used with an MSD 6 Series Ignition, the Blaster SS produces 300 milliamps of current & a maximum voltage output of 40,000 volts!

## MSD Blaster HVC Ignition Coils

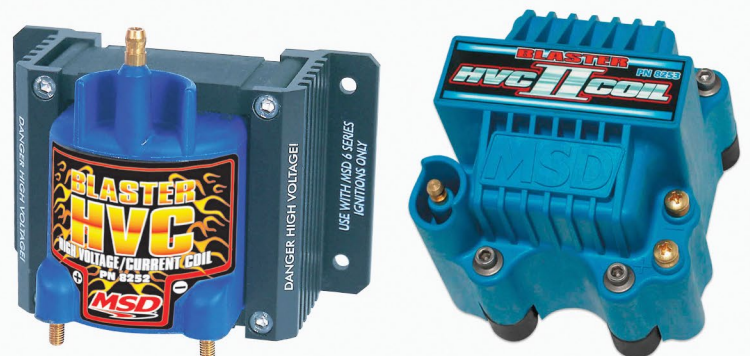

**Blaster HVC Coil:** For use with high rpm, long-duration applications using an MSD 6-Series Ignition.

**Blaster HVC II Coil:** Iron U-Core design produces incredible voltage with lightning quick rise time. For use with MSD 6-Series Ignition Controls.





## HVC II Ignition Coils

HVC II Ignition Coils are high voltage/high current performance coils that are designed to run extremely cool with efficient windings that combine high voltage & current for reduced electricity transfer loss, resulting in maximum voltage & energy.

Pro Power HVC II Coil: Iron U-Core design produces incredible voltage with lightning quick rise time. For use with MSD 7 or 8-Series Ignition Controls.

- Designed for racing applications with an MSD 7 or 8 Series Ignition Control
- New U-core winding design produces more voltage & current
- 70:1 turns ratio & lower primary resistance produce high voltage output
- Windings are encased in fracture resistant compound for vibration resistance
- Dupont Rynite housing with isolated tower & brass primary terminals

RED  
M468261



BLACK  
M4682613



## Coil Packs

Mitsubishi/Dodge/Mini Coil Packs

GM Coil Pack  
2 Tower Style

Ford Mustang/F150  
(1995-1998 4.6L DOHC/  
SOHC)

MSD offers these two 4-tower coils as replacements for a variety of years ranging from 1994-2003 on vehicles including Mitsubishi, Neons and others.

MSD designed these Coils by combining our Blaster Coil experience with E-core coil efficiency. Each coil has a unique turns ratio plus there is lower primary resistance than the stock coil. This all amounts to a bolt-in replacement coil that produces more output voltage.

They are designed with improved materials and windings to produce a stronger spark. This improved spark helps burn the fuel mixture more efficiently, resulting in smooth idle and improved midrange rpm power.



## Ignition Coils

Looking to replace your worn out LS coils with a more efficient upgrade? The new MSD Blaster LS Coil line is ideal for your modern GM muscle car or truck. The coils are designed as a bolt-in replacement yet have been thoroughly tested & detailed by our experienced engineering team.

'99-'09 GM L-Series Truck	M4682648
'05-'13 LS2/LS3/LS4/LS7/LS9	M4682658
'99-'07 GM L-Series Truck	M4682638
'98-'06 GM LS1/LS6	M4682628
4.6/5.4 SOHC 2v	M4682428
'04-'08 SOHC 4.6/5.4 3v	M4682438
'99-'14 DOHC 4.6/5.4 4v	M4682448
'03-'05 HEMI 5.7	M4682568





Powermaster starters pack torque into a lightweight unit that can stand abuse. Powermaster builds several types of starters for most applications from 160 - 260 ft.-lbs., including gas & diesel engines.

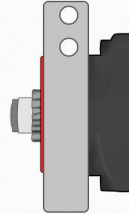

**INFI™ CLOCK STARTER ADAPTERS**

Powermaster Infi-Clock starter adapters allow you to mount your starter to clear most oil pans & headers. These adjustable machined billet aluminum mounting blocks are available to help you install your Powermaster Infi-Clock starters.

**DUAL DRILLED 153 & 168 TOOTH CHEVROLET V8 ENGINES**

All 9000 & 9004 starters are dual drilled to fit 153 or 168 tooth in-line pattern 1st generation Chevrolet V8 engines

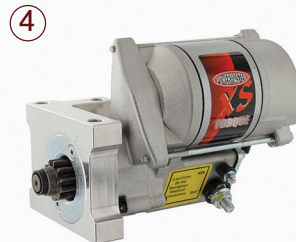
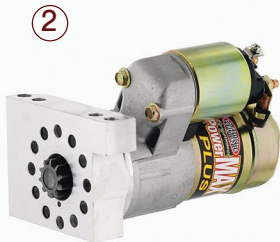
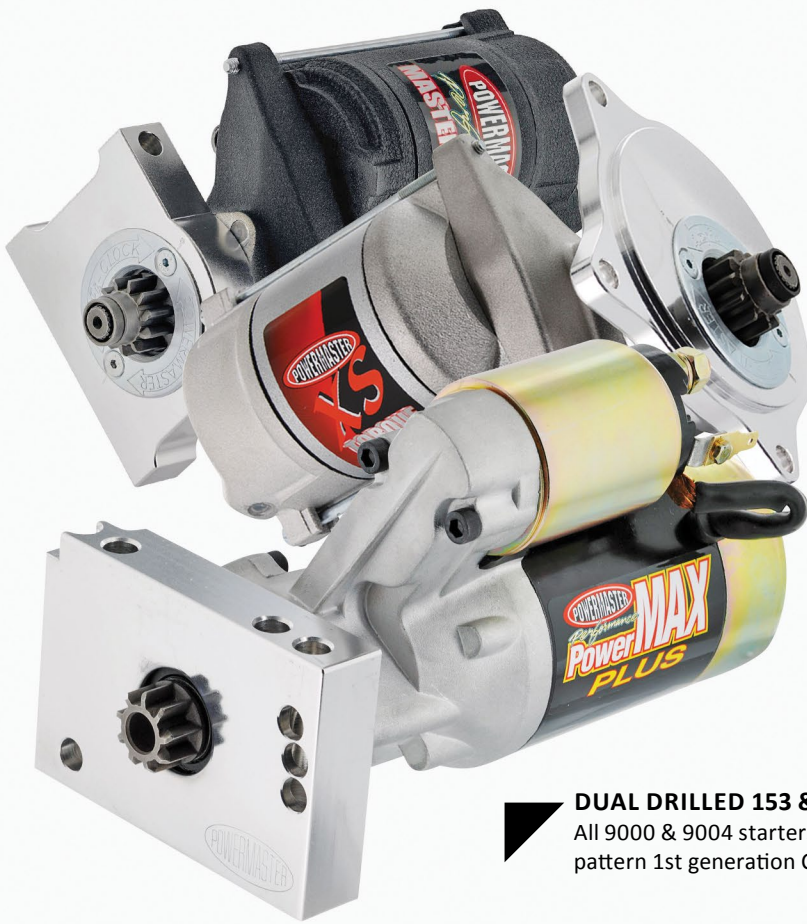

Powermax Starters are designed for cranking power in engines with up to 10:1 compression. These gear reduction starters feature a permanent magnet for high efficiency & an overall total weight of 8 lbs.

Powermax PLUS Starters are designed for cranking power in engines with high compression. These clear most exhaust headers & kickout style oil pans.

The Powermaster MasterTorque starter is an excellent choice for mild race or high-performance street applications where heat soak is the main concern.

Powermaster XS Torque Starters are an excellent choice for highly modified engines or applications where heat soak or limited space is a concern (street rods, race cars, or street machines with close proximity to headers, etc.).

Ultra Torque Starters are designed for cranking power for over 18:1 compression. Features 4.4:1 gear reduction & 2.5KW with 3.4 HP. Works with oversized kickout oil pans & is water & corrosion resistant.

*Which Starter is right for you?*

**1 PowerMax Starters**

Chevy Mini Starter 168 Tooth Stgrd. Bolt	P669200
--	---------

**2 PowerMax PLUS Starters**

Natural Starter Chevy Mini 1.4KW -	P669000
Chrome Mini GM Starter for 153/168 Tooth	P6619000
Chrysler Mini Starter [Denso style] Natural	P669300

**3 Master Torque Starters**

Staggered Bolt	P669612
Pontiac/Oldsobile 166T	P669610
Ford 289-302-351W/C A/T & 5-speed M/T	P669603
Chevy 168/153 Tooth	P66960
Chrysler	P669613
Staggered Bolt	P669612

**5 UltraTorque Starters**

GM 153/168T, 250 ft-lbs Natural	P669400
---------------------------------	---------

**4 XS Torque Starters**

Chevy Stgrd. mnt. (3-Hole) 168 Toot	P669526
Chevy Stgrd. mnt. (3-Hole) 168 Tooth	P669523
Jeep 4.0L	P669516
Buick 455 Chrome	P669511
Pontiac/Olds w/Chrome Bolts Chrome	P669510
Chevy 168 Tooth Flywheel	P669500
Chevy 153 Tooth Flywheel	P669503
Ford 289-302-351W/C A/T & 5-speed M/T	P669502
Ford 390-427-428 "FE" Only	P669506
Ford 289-302-351W/C 3- & 4-speed M/T	P669504





Available in a variety of amperages & styles, allowing you to choose what you need for your ride & the accessories you run. From original look to Upgrade versions & various CS, SI, & 3-6G styles We also offer an extensive amount of **Racing Alternator** solutions.

**CHEVY/GM**

12si-Style <b>150 Amp</b> ; V-Belt Pulley; <i>Black</i>	P6657294
12si-Style <b>100 Amp</b> ; V-Belt Pulley; <i>Natural</i>	P667294
12si-Style <b>100 Amp</b> ; V-Belt Pulley; <i>Chrome</i>	P6617694
12si-Style <b>150 Amp</b> ; V-Belt Pulley; <i>Natural</i>	P6647294
12si-Style <b>100 Amp</b> ; V-Belt Pulley; <i>Satin</i>	P6627295
XS Volt CS130 Straight Mount 6.61"; <b>140 Amp</b>	P66578028
Delco-Style <b>100 Amp</b> ; <i>Natural</i>	P668002
Denso-Style 118mm Race <b>150 Amp</b> 1-Wire; <i>Black</i>	P668142
CS144 Style <b>200 Amp</b> ; <i>Natural</i>	P6648202
CS130D 5.31" Rear Post <b>165 Amp</b> ; <i>Natural</i>	P6648206
CS130 <b>140 Amp</b> Offset Left Mount 4.63" Rear Post; <i>Natural</i>	P6647861
CS 130 Straight Mount 6.61" <b>140 Amp</b> ; <i>Chrome</i>	P66378021
Retro 10DN Externally Regulated 70 Amp; <i>Chrome</i>	P6617102

**CHRYSLER/MOPAR**

Chrysler CS130 with External Fan <b>140 Amp</b>	P66837529
Chrysler CS130 with External Fan <b>140 Amp</b> ; <i>Natural</i>	P66847529

**FORD**

1G Style Ford <b>75 Amp</b> ; <i>Chrome</i>	P6617078
Ford PowerGEN <b>90 Amp</b> Swing Mount; <i>Black</i>	P6682101
Motorcraft <b>150 Amp</b> Upgrade, Serpentine Pulley; <i>Chrome</i>	P6637140
Motorcraft <b>100 Amp</b> Upgrade,, Serpentine Pulley; <i>Chrome</i>	P6637100
Motorcraft <b>150 Amp</b> Upgrade, Serpentine Pulley; <i>Black</i>	P66857140
Motorcraft <b>100 Amp</b> Upgrade, Serpentine Pulley; <i>Black</i>	P66857100
Motorcraft <b>150 Amp</b> Upgrade; <i>Satin</i>	P66837140-360

Available Finishes **IN-STOCK**

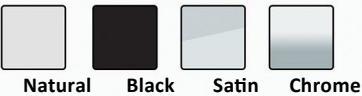

**Snug-Mount/Low Mount Billet Alternator Brackets**

If your rig is anything but stock, & underhood space is at a premium, then these Powermaster alternator brackets are perfect. They come in a variety of designs for nearly any alternator combination in almost any location. Their extra-tough design ensures proper belt alignment in the harshest conditions.

**93MM Pro Series (#8162)**

<b>LOW</b>	<b>SBC #896</b> <i>Mounts on either side.</i>	<b>BBC #895</b> <i>Mounts on either side</i>
<b>SNUG</b>	<b>SBC #875</b> <i>Driver-side ONLY.</i>	<b>BBC #880</b> <i>Mounts on either side</i>

**CS121 Pro Series (#8062/#8072)**

<b>LOW</b>	<b>SBC #898</b> <i>Mounts on either side.</i>	<b>BBC #897</b> <i>Mounts on either side.</i>
<b>SNUG</b>	<b>SBC #881</b> <i>Driver-side ONLY.</i>	<b>BBC #882</b> <i>Mounts on either side</i>

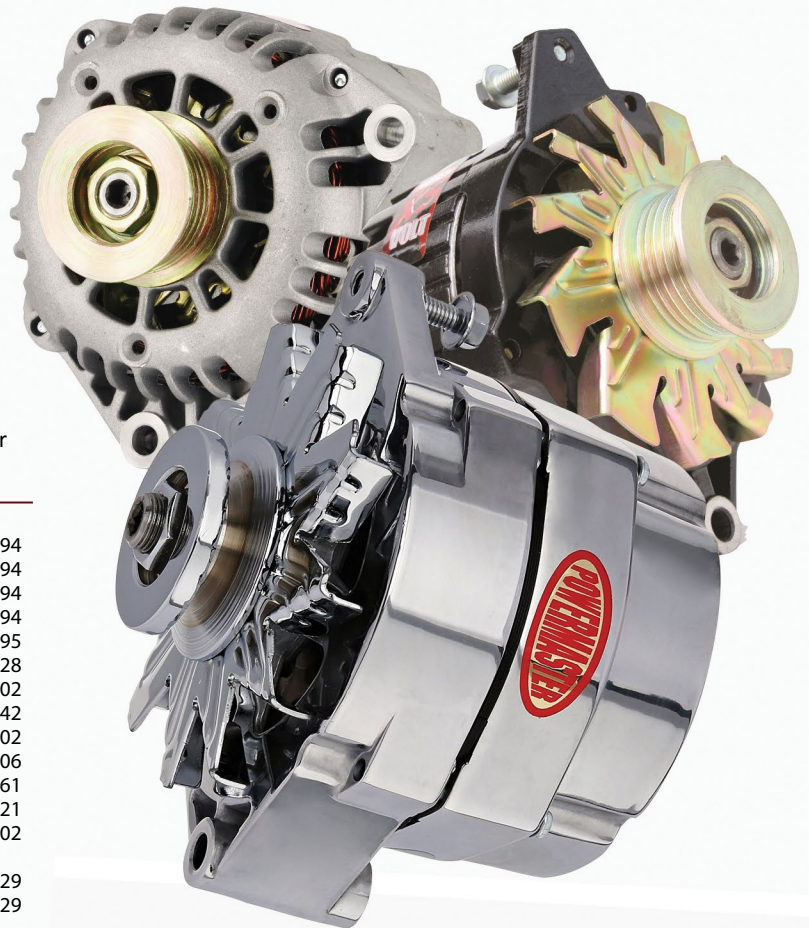

**RACING ALTERNATORS**

Ask about choosing the right AMP Load, Charge Wire, Pulley System Ratios.

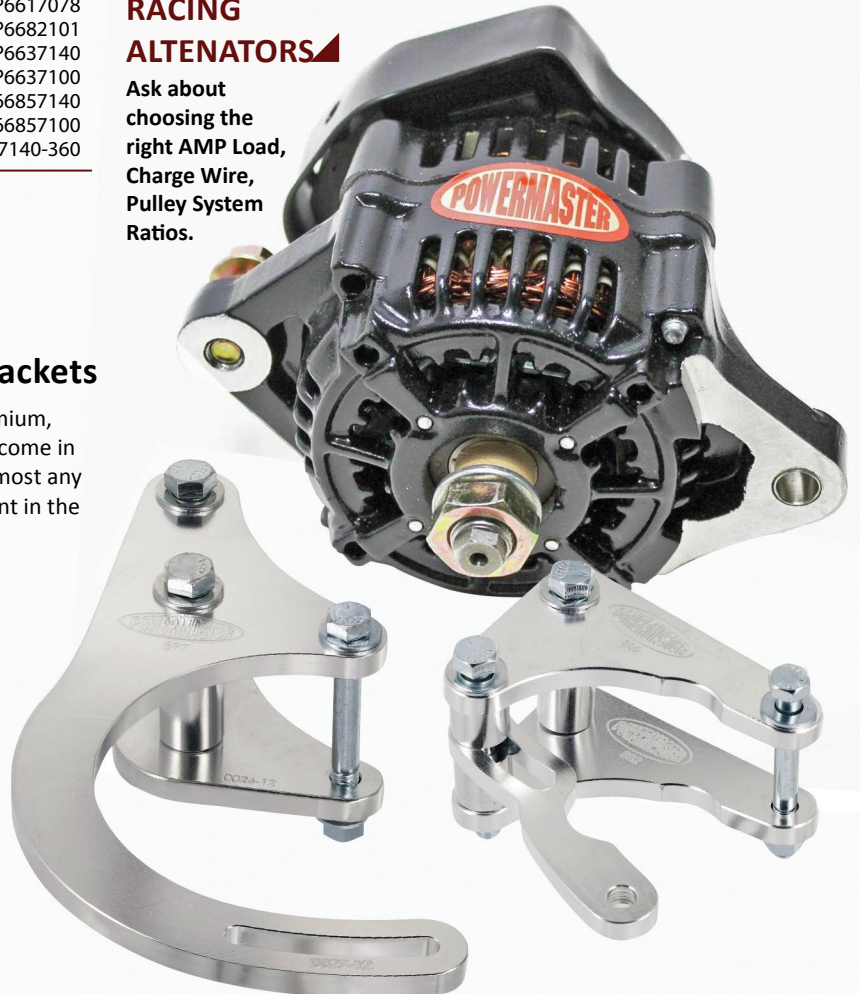



**OPTIMA**  
BATTERIES



## REDTOP

The REDTOP high-performance AGM battery is the ultimate starting battery & is designed to deliver a strong burst of ignition power for a reliable start-up every time. It has high-power delivery & extreme resistance to the most common causes of battery failure.

## YELLOWTOP

The YELLOWTOP high-performance AGM battery is one of the few true dual-purpose automotive batteries available. With premium cranking power & impressive cycling capability, this heavy-duty battery is also perfect for modern accessory-loaded vehicles. Low internal resistance also provides more consistent power output & faster recharges.

## BLUETOP

The BLUETOP is a high-performance AGM battery with exceptional running time & more recharges than you'd get out of a traditional battery. This flexible boat battery & RV battery is ideal for those who need a sure-starting, strong-cranking, maintenance-free power source.



## AGM Batteries

NEW AGM technology is being developed by XS to make vehicles faster with the reduction in weight. There are dozens of different XS Power batteries & automotive battery chargers to choose from. From 12 volt to 16 volt, you'll find the XS Power you need!

### S SERIES LIGHTWEIGHT STARTING RACE

12V AGM Starting Battery, CA: 240A; 11lbs	S545
12V AGM Starting Battery, CA: 320A; 15.4lbs	S680
12V AGM Starting Battery, CA: 550A; 23.5lbs	S925
12V AGM Starting Battery, CA: 725A; 33.25lbs	S1200

### D SERIES 14V DEEP CYCLE

14V AGM Battery, CA: 550A; 23.5lbs	D1400
------------------------------------	-------

### D SERIES 16V DEEP CYCLE

16V AGM Battery, CA: 675A, 48lbs	D1600
----------------------------------	-------



## Billet Tray - Optima 34/78

Billet Aluminum Battery Tray For Optima Group 34/78 Batteries



## 680 Side Mount

680 Stamped Aluminum Side Mount Box with Window



## 925 GM Direct Mount

S925 GM Direct Mount & Universal Mounting Kit



## SEALED BATTERY BOXES



### **TAYLOR** Aluminum Battery Box Kit

Complies with NHRA Rule 8:1. Required by NHRA when there is no firewall between driver's compartment & battery. Fits most battery sizes. 3 piece .040" aluminum box design allows access without removing the battery from the box. Dimensions: 13.5" long x 9.5" wide x 10" high.

### **MOROSO** Sealed Battery Box

Sealed Battery Boxes from Moroso are made from injection molded acid resistant Polyethylene plastic & is fully approved for racing by the NHRA, IHRA, & SCCA. With outer dimensions of 10-1/2" deep, 13" wide, & 9-1/2" tall, this battery box will hold a Series 24 battery with either top-post or side-post terminals.

### **QUICKCABLE** Group 27 Battery Box

QuickCable's Standard QuickBox 120172-001 fits all 27 group sized batteries, including spiral cell & high performance models. With features like the QuickLock cover, mounting holes in the handles, & materials tested to perform in all conditions, these are the battery boxes of choice.

### Hold-Down Kits

Taylor battery hold-down kits include just the essential hardware & can work with custom battery trays, as well as many stock battery trays.



### Diamond Back Battery & Starter Cables

Get Taylor Battery Cables with quality components that deliver the highest possible energy flow. Available in different lengths & gauges to meet your requirements.

Starter-to-Switch 4 Gauge 18"	20118
Starter-to-Switch 4 Gauge 24"	20124
Battery Cable Top-Post 27" 4 Gauge	20027
Battery Cable Top-Post 24" 4 Gauge	20024
Battery Cable Top-Post 31" 4 Gauge	20031
Battery Cable Top-Post 48" 4 Gauge	20048
Batter Cable Top-Post 53" 4 Gauge	20053



### Battery Terminals & Disconnect Switches

Required for many classes by sanctioning bodies, including NHRA & SCCA. Mounts easily to provide an externally accessible on/off switch in case of emergency.

Battery Disconnect Switch 20A	M2874100
Battery Disconnect Switch 175A	M2874101
Battery Disconnect Switch 300A	M2874102
Remote Jump Terminals Universal 6-36VDC	M2874140
Battery Quick-Disconnect Cables	M2874155
Battery Disconnect Top Terminal	M2874103
Battery Disconnect Side Post Terminal	M2874104





PowerBraid / ClassicBraid  
Wire Loom Kits

# PAINLESS

## Universal / Application Specific Wiring Harnesses

Painless products are designed by real engineers using the latest in diagnostic equipment to ensure consistency in manufacturing for an accurate & easy Painless installation. They specialize in wiring harnesses that make it easier for the installer to assemble, or build, an electrical system that is trouble-free!

EFI - '99-'06 GM Vortec 4.8/5.3/6.0L	60217
C.S.I. Engine Harness Charging, Starting, & Ignition	30830
Universal GM Muscle Car Wiring Harness 1969-74 GM Car	20102
Universal Muscle Car Wiring Harness 28-Circuit Harness	20104
Universal Fuse Block 14-Circuit	30001
Universal Mini Fuse Block 16-Circuit	50101
CirKit Boss Auxiliary Fuse Block Kit	70118
Fan-Thom II Electric Fan Relay Kit	30103
<i>With Thermostat Protection SPST 40 Amp Relay</i>	
Dual Battery Control System 250 Amp	40102
High Amp Alternator Shutdown Relay Kit 250A Solenoid	50105
Roll Bar Rocker Switch Panel 6-Switch - Vert. Mount	50506
Roll Bar Rocker Switch Panel 6-Switch - Horiz. Mount	50302
Roll Bar Rocker Switch Panel 8-Switch	50303
Fuel Pump Relay Kit 30 Amp Heavy Duty Relay	50102

### PAINLESS POWERBRAID WIRE WRAP

The flexible, semi-rigid, nylon-like split design closes around the wire bundle without the need for additional taping or zip ties. The 25% edge overlap allows for easy installation over splices & inline connectors without exposing wires & cables.

### PAINLESS CLASSIC BRAID WIRE LOOMS

The laterally split design closes around the wire bundle without the need for additional taping or zip ties. The 25% edge overlap allows for easy installation over splices & inline connectors without exposing wires & cables. It looks a lot like antique cloth wiring!

# K4 SWITCHES

We stock a wide array of **12V Switches** available in **multiple amperage ratings**. From Toggle & Rocker Switches to Push Button & LED Indicators, SK Speed has everything you need to complete any custom electrical switch wiring projects.



#### TOGGLE SWITCHES

- ON/OFF & OFF/Momentary ON
- O-Ring Sealed, Triple Sealed, Illuminated Versions available.

#### ROCKER SWITCHES & GUARDS

- ON/OFF & OFF/Momentary ON
- Standard & Round Rocker Illuminated Versions Available.
- Switch Guards Available in various styles.

#### PUSH BUTTON SWITCHES

- ON/OFF & OFF/Momentary ON.
- Illuminated Versions Available.

#### LED INDICATOR LIGHTS

- Red, Green, Amber, Blue Colors Available w/ Black or Chrome Bezels.
- Various Indicator Lens; Fuel Pump, Turn Arrows, Fan, Driving Lights.



We STOCK a large variety of switch types in multiple amperage ratings!





## 12/14/16 Volt RACING INTELLICHARGER



- Compatible with 12V, 14V & 16V Batteries
- AGM/Gel, Deep cycle & Maint. free COMPATIBLE
- Charging Levels: 5A, 15A & 25A
- LED indicators plus Digital Voltage/Amperage Gauge
- 110V/220V Input Operation

### Perfect for TRACK DAYS!

The IntelliCHARGER is an advanced battery charger designed specifically for high performance lead-acid batteries. This charger combines the reliability of a transformer & MOSFET rectifier assembly with an advanced microprocessor control board to create a battery charger that can rapidly & safely recharge 12V, 14V & 16V flooded, maintenance free, deep cycle, gel-cell, & AGM (Absorbed Glass Mat) batteries in several sizes. The front panel switches, LED indicators, & charge meter make the IntelliCHARGER very easy to use.



## Smart Battery Chargers

CTEK offers battery chargers for car batteries, boat batteries & motorcycle batteries for professionals as well as consumers. We have chargers for charging in cold & AGM batteries.

### MULTI US 3300 - 561581

Versatile battery charger in a compact format that makes it convenient & easy to charge & maintain all household vehicles. The special cold mode means that you can also charge during cold winters days without problems.

### MULTI US 7002 - 56353

Ideal battery charger for your caravan, car & boat. The battery charger is well suited for all-year use. Thanks to its SUPPLY mode the battery charger provides power even without a battery.

### MULTI US 25000 - 56674

8-step, fully automatic primary switch mode battery charger. A powerful charger for 12V batteries that require rapid charging such as in garages, RV's, boats & of course cars.

### US RACING MURS 7.0 - 56830

Charger that offers state of the art technology that was previously only found in CTEK's 12V product range. The charger is perfect for your 16V racecar or audio application no matter what the weather, temperature or conditions.



Each Battery Charger includes two interchangeable connection leads, one with clamps, & one with eyelet terminals



# Autogage

## Single, Double, & Triple Gauges Consoles & Tachometers

Available in popular sizes, single or multiple consoles, two color schemes (black face with white accents & white face with black accents), & some with chrome trim, "Autogage" offers many economical options for street & street performance vehicles. Known for a wide variety of black & chrome tachometers & underdash panels for 1950s & '60s muscle cars, Autogage gauges include hardware & mounting accessories, & they are designed for easy installation.



### Single 2-1/16" (Face/Bezel Color)

Vacuum, 30 in. Hg  
 Voltmeter, 10-16 V  
 Water Temp., 100-280°  
 Oil Pressure, 0-100 psi

### Double Consoles 2-1/16" (Face/Bezel Color)

Water Temp., Oil Press. (Black/Black)  
 Water Temp., Oil Press. (White/Black)

### Triple Consoles 2-1/16" (Face/Bezel Color)

Water Temp., Voltmeter, Oil Press. (Black/Black)  
 Water Temp., Voltmeter, Oil Press. (White/Chrome)  
 Water Temp., Voltmeter, Oil Press. (Black/Chrome)

### Triple Consoles 1-1/5" (Face/Bezel Color)

Water Temp., Voltmeter, Oil Press. (Black/Black)



**Pedestal-Mount Tachometer 5"**  
 10,000 RPM  
 (Black/Brushed Aluminum)

### Pedestal-Mount Tachometers 3-3/4"

8,000 RPM w/ Light (Black/Black)  
 8,000 RPM w/ LED Light (Black/Black)  
 8,000 RPM (Black/Black)  
 8,000 RPM (Black/Chrome)  
 8,000 RPM (White/Chrome)

### Triple Consoles 2-5/8"

Water Temp., Voltmeter, Oil Press. (White/Black)  
 Water Temp., Voltmeter, Oil Press. (Black/Chrome)  
 Water Temp., Voltmeter, Oil Press. (White/Chrome)



## Wideband Air/Fuel Ratio Gauge

A must if you want to maximize your engine's power & safety. Digital center readout with green LEDs at the outer perimeter for easy acquisition. Interchangeable black & white faceplates included for customizing gauge appearance.



## Digital Oil Pressure Gauges

Unsurpassed accuracy & speed. Plug & Play harness & sensor included. 0-5V analog output included for use with data loggers. Interchangeable black/silver bezels & black/white faceplates. Auto-dimming gauge face & read out lighting. 24 green LED outer display lights. Three digit readout in center.



## Digital OBD-II Scan Gauge

Capable of displaying over 100 parameters, two at a time at an adjustable rate of up to 20x per second. Available in a variety of display colors. Custom faces are also available!





## One Gauge, 2 Faces Phantom II Gauges

Mechanical & electrical (full or short sweep) in five diameters, each Phantom II Gauge has through-the-dial lighting & an LED pointer. The gauge faces have a reverse lighting effect, white during the day & dark with illuminated accents at night.

Available in Pedestal-Mount & In-Dash Versions  
SIZES: 2-1/16" | 2-5/8" | 3-3/8" | 5"



## Ultralite II

Each Ultra-Lite II Gauge has a silver face & black accents during the day, LED pointer, & through-the-dial lighting. At night, a unique reverse lighting effect alters the face of the gauge to dark with illuminated accents.

2-1/16" | 2-5/8" | 3-3/8" | 3-3/4"



## Pro-Comp

Electrical or mechanical (some liquid-filled) & in four diameters, these gauges are designed for pro racers. They consist of the finest components for dependability & accuracy, & gauge faces offer ultimate visibility.

2-5/8" | 3-3/8" | 3-3/4" | 5"



## Cobalt

Cobalt Gauges illuminate with a brilliant blue light that shines through the dial of the face to light up the numbers. The gauges are easy on the eyes and, compatible with standard, electronic, & most high-performance racing ignitions, they are perfect for street rods, muscle cars, imports & trucks.

2-1/16" | 2-5/8" | 3-3/8" | 3-3/4"



## Sport-Comp II

Mechanical & electrical (full or short sweep) & in five diameters, each Sport-Comp II Gauge has a black face, white accents with through-the-dial lighting, & an LED pointer.

2-1/16" | 2-5/8" | 3-3/8" | 3-3/4" | 5"



## American Muscle

Combining Auto Meter's signature white Hi-Def LED illumination & glowing red pointers with spun aluminum dials & embossed detail. Finished with chrome super bezels.

2-1/16" | 3-3/8" | 5"



### Single & Dual Pillar Gauge Pods

Get the gauge information you need with a great custom look. No more guilt from altering your dash. AutoMeter & Autogage Pillar Pods are designed to mount gauges in the driver's field of vision so that they also blend perfectly with the interior. Pillar mounted gauge pods are perfect for smaller add-on gauges that are often installed on performance cars & trucks.

### Single, Dual, Tripple Gauge Mounting Panels

Available in Single, Dual, & Tripple gauge configurations, these quality mounting panels mount gauges with ease & style. If you are replacing or adding gauges to your vehicle, consider a gauge panels to install the gauges in.



▶ **ANGLE RINGS**  
Quality molded black plastic rings angle gauges toward driver for optimum viewing. Requires mounting bracket modification.

▶ **GAUGE MOUNTING CUPS**  
Gauge cups allow you to mount your gauges on the dash, below the dash, or outside on your hood cowl for that Pro Street look. With their availability for several gauge diameters, as well as their great looks & functionality, these gauge mounting cups are sure to be hits.

**i** WE HAVE THE LARGEST STOCK OF GAUGES, GAUGE MOUNTING SOLUTIONS & ACCESSORIES FOR AN INSTRUMENTATION CONFIGURATION SETUP!



### Tire Pressure Gauges

AutoMeter's excellence continues with their performance tire pressure gauges. Tire pressure is critical for top performance. These rugged & reliable gauges from AutoMeter offer precise tire inflation measurements in digital & analog styles.

Available in 0-15PSI | 0-40PSI | 0-60PSI



### Tire Pressure Gauges

Moroso tire pressure gauges are individually calibrated for accuracy within 2 percent. They feature a large-diameter dial face that is easy to read, & their hardened swivel chuck rotates a full 360 degrees for positive swivel attachment. Plus, the hose has a finger-operated air-bleed valve.



### Digital Tire Pressure Gauges

The easy to read digital display has a peak hold function, controlled air bleed buttons, & LCD backlighting. This easy to use digital tire gauge will measure tire pressure from 0 to 100 psi in increments of 0.01 psi. It also features an auto-OFF setting & 2 modes of operation.





### 2-1/2lb, 5lb, 10lb, & 15lb Nitrous Bottles

NX nitrous bottles feature a tough & attractive powdercoated finish. Bottles available with billet aluminum Lightning 500 bottle valves & 0-1500psi nitrous pressure gauges.

### CARBURETOR & EFI MAINLINE NITROUS SYSTEMS

MainLine Systems benefit from the years of research & development that made Nitrous Express the leader in the nitrous world, but at a price even the most budget-restricted racer can afford. Just the basics, no frills, just rock solid performance at rock bottom prices.



### Nitrous Pressure Gauges

This high accuracy liquid filled 2" nitrous pressure gauge reads from 0 to 1500 psi. Features a billet aluminum manifold that has two 1/8 npt ports allowing you to connect the nitrous gauge as well as another 1/8npt accessory in-line with a -6AN or -4AN line.



### Nitrous Purge Systems

This System includes a Lightning solenoid, push button for activation, & a vent tube to direct the purged nitrous out of the solenoid. Also included is a -4AN or -6AN manifold to run in-line with your nitrous feedline.



### TPS Activation Switches

The new T.P.S. Autolearn, configures wide open throttle voltage with the simple push of a button. It comes complete with an adjustable switch module, relay, wiring harness, & all necessary hardware for a complete installation.





## CUSTOM HARDLINE WET NITROUS SYSTEMS

Custom fabricated hard lines & solenoid brackets are engine specific & make installation quick & easy! CNC billet spray plates with engraved logo, jetting from 50HP to 200HP, fuel & nitrous solenoids, brackets, activation switch & wiring is included along with an empty 10lb. bottle.\*Intake Manifold not included.

*We stock various application specific systems such as:*

- '98-'02 Camaro/ Firebird LS1 w/ stock manifold
- Late Model 5.7L/ 6.1L Hemi w/ 80mm plate
- '05-'10 Mustang GT 4.6L
- '96-'04 Mustang GT 4.6L
- 2011 - UP Mustang Gt 5.0L

## NITROUS PURGE KITS

Release trapped air with Nitrous Outlet purge kits for a "cloud" of performance! Air in your main feed line can cause delays or surges in your nitrous system. Evacuating air pockets can help improve ET times at the track, & as you purge, a massive white cloud of nitrous will emerge to grab the attention of onlookers. Your kit includes all hardware, a relay & harness, & flexible aluminum line. Nitrous Outlet purge kits deliver added performance for your racer & the crowd!



## DIRECT FIT SWITCH PANELS

Nitrous Outlet switch panels are designed to give you a clean look--and make using multiple nitrous-related options easier to manage with the use of large, easy-to-reach switches. These panels are made from water jet-cut aluminum & have a black anodized finish & a custom fit. They'll work with any brand of nitrous system & accessories, & with no drilling needed, will mount to your cup holder, ashtray, or console, depending on the application.



## BILLET BOTTLE BRACKETS

Secure your nitrous bottle with Nitrous Outlet billet aluminum nitrous bottle brackets. Machined from 6061 billet aluminum, they offer several options, from bottle brackets only to vertical/horizontal or single/dual bottle kits with cradles. You can also choose a show-stopping polished finish, quick-release knobs, & rubber insulators.





## MECHANICAL FUEL PUMPS

### Performer RPM Series

These high performance Street Fuel Pumps feature a high quality three stage polished finish. The unique valve design improves flow quantity & quality, & will support engines up to 600 hp. High-volume, 3/8" NPT inlet & outlet surpasses the capacity of conventional models. Produces 6 psi & does not require a regulator. For gasoline only. Clockable lower housing can be rotated for best Inlet/Outlet alignment.

#### 110 GPH

##### CHEVY

Small-Block Chevrolet	E111721
Big-Block Chevrolet	E111722

##### FORD

289-351W Ford	E111725
390-428 FE Ford	E111724
429/460 Ford	E111726

##### CHRYSLER

Small-Block Chrysler	E111720
Big-Block Chrysler	E111723

##### PONTIAC

Pontiac V8	E111713
------------	---------



### Victor Series

A must for drag racing, circle track racing, street machines or any application that demands a high-volume fuel delivery. High-volume 3/8" NPT inlet & outlet orifices surpass the capacity of conventional models. Produces 10 psi & must be used with an external fuel pressure regulator

#### 130 GPH

##### CHEVY

Small-Block Chevrolet	E111711
Big-Block Chevrolet	E111712

##### FORD

289-351W Ford	E111715
429/460 Ford	E111718



## UNIVERSAL MICRO ELECTRIC FUEL PUMPS

Edelbrock Universal Micro Electronic Fuel Pumps deliver maximum performance in a compact package. They feature a durable simple design that reduces the chance of vapor lock & flooding. Edelbrock Universal Micro Electronic Fuel Pumps are easy to install & operate quietly so you won't know its there! Includes fuel pump, filter, mounting hardware & instructions for a hassle free installation. Available for gasoline & diesel applications.

Gasoline/E85 2-3.5psi	E1117303
Gasoline/E85 4-7psi	E1117301
Diesel 4-7psi	E1117302
Replacement Filter Element - 40 Micron	E1117311
Replacement Filter Element - 100 Micron	E1117312



**Holley** Carbureted  
**Electric Fuel Pumps**

The world famous Red®, Blue® & Black® fuel pumps are the most recognized performance pumps of all times. They have been powering racing legends & street enthusiasts alike since the early 70's. Their time proven rotor/vane design is known to get the job done in an affordable package.

**Red Standard Pressure Electric Fuel Pump**  
97 gph / 367 lph (free flow) + 71 gph @ 4 psi Line Pressure  
Preset to approx. 7 psi; 3/8" NPT Inlet/Outlet; Gasoline Only

**Blue Max Pressure Electric Fuel Pump & Pressure Regulator**  
110 gph / 416 lph (free flow) + 88 gph @ 9 psi Line Pressure  
Preset to approx. 14 psi; 3/8" NPT Inlet/Outlet; Gasoline Only

**Black Pro Series Pressure Electric Fuel Pump**  
140 gph / 530 lph (free flow) + 120 gph @ 9 psi Line Pressure  
Preset to approx. 14 psi; 3/8" NPT Inlet/Outlet  
Gasoline, Alcohol & Methanol Compatible



**HP 150 Fuel Pump**

The Holley HP 150 series fuel pump has an exclusive gerotor gearset that quietly & efficiently pumps the fuel without the noise of traditional vane pumps.

Flows 150 GPH free flow  
Flows 140 GPH at 7 psi



**Holley Mighty Mite Electric Fuel Pump**

They're big on performance, but small in size! They're quiet, easy to install & work with gas, diesel, blended alcohol & E85!



**Electric Fuel Pumps**



**125 GPH- QFT30-125-1R**



**175 GPH- QFT30-175**



**427 GPH  
QFT30-427**



**High-Output Electric Fuel Pump**

Built for the most demanding drag racing applications, Pro Series pumps feature hard anodized billet aluminum housings, a rugged six-vane pump, all armatures are epoxy coated to secure windings and extend motor life. -10AN in/out & includes internal bypass & provision for fuel pressure gauge. Designed for engines between 800-2,500 HP.

These Quick Fuel electric fuel pumps are specifically designed for drag race use. 175GPH features a built-in internal/external adjustable bypass, a built-in fuel pressure gauge port, & -8 AN fuel inlet & outlets. 125GPH is internally preset approx 14psi & 3/8" NPT in/out.





## A1000 In-Line Fuel Pump

Aeromotive A1000 fuel pumps are the pumps that started it all--they are durable, reliable, good looking, & they support high horsepower. Featuring a 600 lbs./hr. flow rate at 13.5 V & 45 psi, these A1000 fuel pumps are perfect for the daily driver that doesn't run like a daily driver.

## A750 In-Line Fuel Pump

Feed your beast with these new A750 fuel pumps. Beautiful, compact, durable, & reliable; these pumps will fuel the fire whether it's naturally aspirated, nitrous enhanced, blown, or turbocharged. Designed to fuel anything from 150 to 800 hp.



## Stealth 340 In-Tank Fuel Pump

The Aeromotive 340 Stealth is a high-output, in-tank, electric fuel pump that fits most popular EFI applications. The Aeromotive 340 is a compact, lightweight pump that bolts into most existing hanger assemblies. What sets the 340 Stealth Pump apart is its superior flow throughout a wide pressure range.



- Center Inlet - A2711540
- Offset Inlet Inline W/Outlet - A2711542
- Offset Inlet - A2711541
- 1982-97 Chevy/GMC - A2711569



## High-Performance Fuel Pumps

GSS pumps are compatible with a wide range of vehicles, feature unsurpassed quality, durability & performance, & are designed & manufactured in the USA.  
 255lph - W67GSL392  
 400lph - W67F9000262

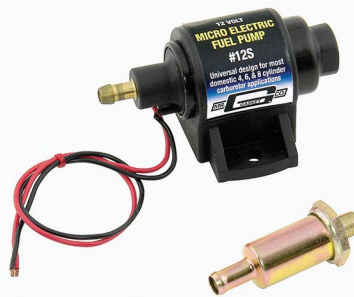

## Micro Electric Fuel Pump

Universal design for most domestic 4, 6, & 8 cylinder carburetor applications. Not recommended for diesel, methanol, ethanol, E85 or Race Fuel applications!!



## High Pressure Elec. Fuel Pump

Multiport EFI systems require a stable fuel supply to maintain best performance throughout the engine's rpm range. **M462225**



### Ford Rail Mount Regulator

Adjustable billet fuel pressure regulators designed to handle the demands of the Ford 4.6L, 5.0L & 5.4L engines. Installs easily on the stock factory fuel rail.

86 – 93 5.0L  
94 – 95 5.0L & 94 – 98 1/2 4.6L



### Universal Bypass Regulator

A dual purpose, universal regulator for EFI or Carbureted & street or strip applications. Base pressure adjustable from 3 to 20 PSI with standard spring, (installed) or from 20 to 60 PSI with high pressure spring (included).



### A1000 Carbureted Bypass Regulator

The A1000 Bypass Regulator was designed for use with our A1000 Fuel Pump or similar style EFI pumps in a carbureted application. This regulator is perfect for naturally aspirated or 'blow-through' supercharged engines.



### Carbureted Fuel Pressure Regulator

Street/Strip Carbureted Applications  
Two Port Adjustable from 4.5 to 9 PSI



### Carbureted Adjustable Regulator

Specifically designed for carbureted street or racing engines, these adjustable regulators offer higher flow, quicker response & less pressure creep than competing two-port designs. Ideal for dedicated nitrous applications.



### Adjustable Fuel Pressure Regulator

Adjustable from 1-6 psi, Includes barbed fittings for use with 1/4", 5/16", or 3/8" fuel hose. For use with carburetor fuel systems only & engines not exceeding 400 HP.



### Modular Fuel Pressure Regulator

Ideal for carbureted nitrous engines, these regulators allow you to "stack" them together to control multiple pressures with a single fuel pump. ORB-10 inlet & outlet flow-through ports (flange stackable)



### Low Pressure Fuel Regulator

Built with premium components & designed to operate within the 1-4 PSI range. Includes mounting bracket & detailed instructions. 3/8" NPT ports.



### EFI Bypass Regulator

Capable of supporting applications up to 1000 HP, the 13129 EFI Bypass Regulator can handle high-flow EFI fuel pumps & the most aggressive street machines; especially those looking for a cleaner, lighter solution where performance is critical or where space is a premium.



### Fuel Pressure Regulator

Billet fuel pressure regulators are the answer when good fuel control is needed at the carburetor. Each unit is constructed as a 2-port design & is fully adjustable.





## Aluminum Street Fuel Filters

Fuel filters are made of billet aluminum for strength & shock resistance. The sintered-bronze 40 micron element can be cleaned or replaced. Fuel filters are designed for carbureted engines making less than 300 hp. Filters are bi-directional & available to fit 5/16" or 3/8" fuel hoses



## Polished Aluminum Fuel Filter

Features a washable sintered bronze filter element for positive filtration, while keeping restriction to a minimum. The unit has 3/8" O.D. inlet/outlet & includes two clamps for easy installation.



## Clearview Inline Fuel Filters

The Mr. Gasket 9706, Inline Clearview fuel filter with chrome ends & a glass body for clear & quick viewing of fuel flow & debris trapped in the 100 Micron white mesh replaceable filter element. Supports up to 400 HP, Includes 1/4", 5/16", & 3/8" in. hose barb fittings. Not for fuel injected applications - 10 PSI MAX Pressure.



## Inline Fuel Filter - Chrome

Polished & chrome-plated to complement other under-hood chrome accessories, these canister fuel filters are perfect for any custom & performance engine. Inlet/outlet openings have a safety bead for positive fuel line retention.

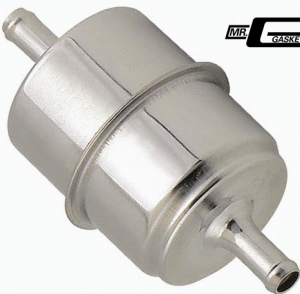

## Inline Fuel Filter - Steel Housing

Construction: Steel  
Inlet Line Size: 3/8" Barb  
Outlet Line Size: 3/8" Barb  
Outside Diameter: 1.938



## Regulated Pressure Fuel Filter

Wix Complete In-Line Fuel Filters are made of pleated papers which prevents leakage of the fuel under compression loads. These filters withstand minimum internal differential pressure of 75psi.

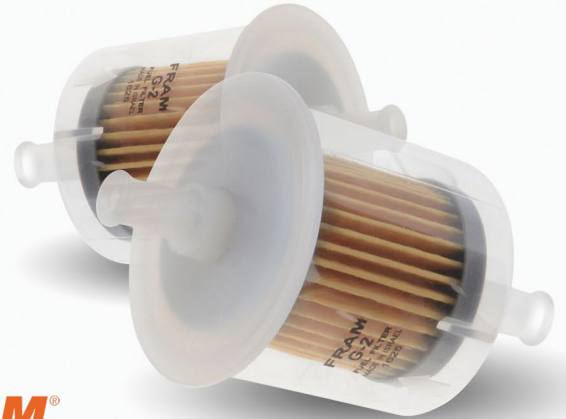

## Clear Inline Fuel Filters

The Fram Fuel Filter line includes Steel & Plastic Conductive In-line Fuel Filters to meet the needs of virtually all engine configurations. Sold Individually

F22G2 Nylon (Clear) - Inlet/Outlet Size: 5/16" Barb  
F22G3 Nylon (Clear) - Inlet/Outlet Size: 3/8" Barb



## FloMax Fuel Filter Systems

FST Performance Fuel Filter Systems provide you with the highest fuel flow & filtration efficiency on the market & are engineered with advanced water-stripping filtration technology. All housings are constructed from lightweight, solid billet 6061-T6 aluminum & contain a self-contained, spin-on filter that prevents fuel system contamination by sealing the system without gaskets, o-rings or seals. These fuel filtration systems will work with gasoline (ethanol/methanol compatible), & racing fuels.



Single Feed

## Fuel Inlet & Filter Kits

These fuel inlets provide a clean & custom plumbing solution. The drop-down design routes the fuel line on the right-hand (passenger side) of the carburetor below the linkage & choke housing.

Chrome Fuel Line Kit - 3/8" Barb (No Filter)	E118126
Chrome Fuel Line Kit -6AN (Filter Included)	E118131
Chrome Fuel Line Kit -6AN (Blue Anodized Filter Incl.)	E118134
Black Fuel Line Kit -6AN (Black Anodized Filter Incl.)	E1181343



## Forged Fuel Line Kits for Dual Feed Carbs

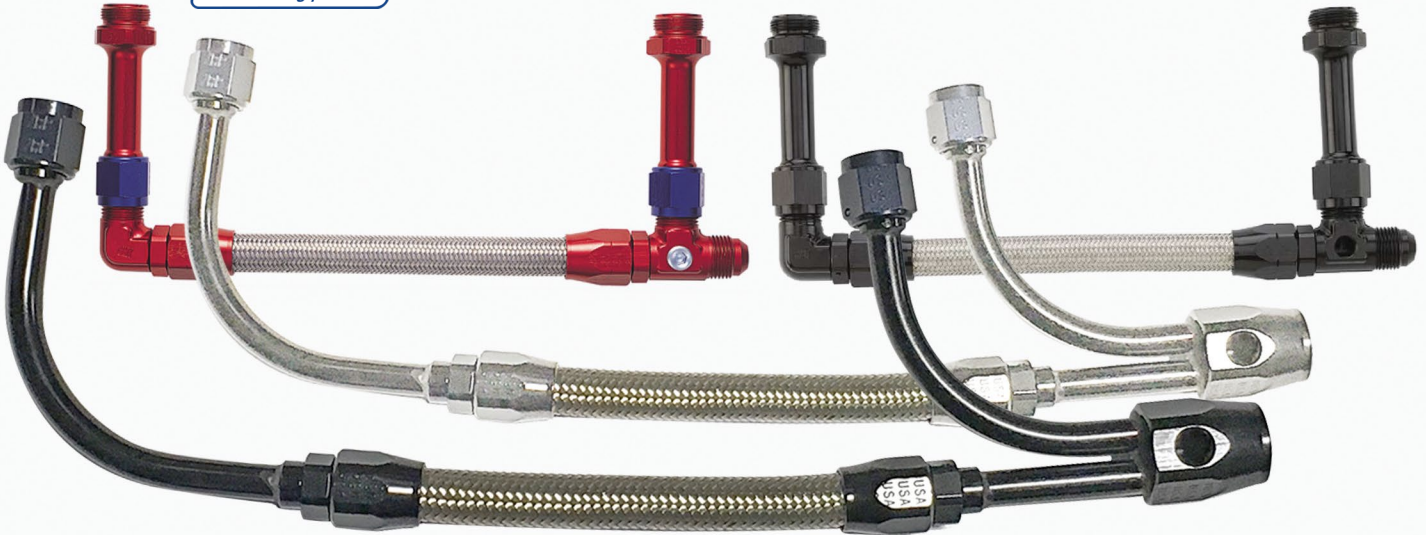

XRP now offers a selection of pre-assembled carburetor kits & adapter fittings for popular Demon, Braswell & Quick Fuel Technology (QFT) carburetors. Choose from either competition-style forged & swept-tube kits.



## -6 & -8 Dual Inlet Carb Kits

These kits are available in both -06 and -08 AN applications for Holley 4150 and 4500-series and Demon/King Demon Carbs in a variety of finishes and AN hose styles. Comes assembled with instructions for easy installation. Fittings features a high quality anodized finish or Russell's unique ultra-bright Endura finish that simulates the appearance of stainless steel.

## Chrome Fuel Line Kit

This fuel line is not only great looking, but is also very functional. It incorporates a small 1 1/2" dia. fuel pressure gauge. The gauge is designed to read in 1/2lb. increments & has a range of 0-15lbs. Inverted flare female inlet thread size 5/8-18.



## CALTRACS Traction Bars

Calvert's CalTracs Traction Bars for cars & trucks are the most innovative traction bar units on the market today. Calvert has specialized in leafspring traction enhancement systems for over 15 years, so if you have a leafspring car, these are the bars for you! From a daily driven street car to a 8-second race car, these traction bars outperform the competition & will have your vehicle hooking harder than ever before. CalTracs are a complete bolt-on assembly with no cutting or welding required that will drastically improve 60 foot times & eliminate axle rotation. CalTracs come gloss black powdercoated & include full color instructions for a hassle-free installation.

- Complete Bolt-On, No Cutting, Welding, or Modification
- For Both Street Driven or Race Cars
- PSCA, NMCA, NHRA Approved



# CALTRACS

## Split-Mono Leaf Springs

Calvert's Split Mono-Leaf Springs are the preferred drag race leaf spring by racing enthusiasts across the world. These leaf springs are substantially lighter than multi-leaf springs, saving unsprung weight. Complete with aluminum bushings in the front eyes & urethane bushings in the rear eyes, split mono-leaves put the power to the ground. Made to work in conjunction with Calvert's CalTracs Traction Bars for maximum traction. Available in various ride height options, & includes heavy duty alignment spring clamps. Sold as a pair.

- Lighter Than Conventional Multi-Leaf Springs
- Aluminum Bushings in Front Eyes
- Urethane Bushings in Rear Eyes
- Works in Conjunction with CalTracs
- Includes Heavy Duty Alignment Spring Clamps



**i** Call for application availability depending on your ride height.

## CF Series 90/10 Front Shocks

Calvert's CF Series 90/10 Front Shocks are specifically designed for maximum weight transfer. These front shocks are lightweight & feature dual valving on compression, allowing the vehicle to settle on the top end. Calvert's CF Series Shocks offer lightning quick separation, making these very cost effective for your street or strip vehicle. Sold Individually.



## CR Series 9-Way Adjustable Rear Shocks

Calvert's CR Series 9-Way Adjustable Rear Shocks are a heavy-duty, industrial steel bodied shock that helps enable your vehicle to a precise, controlled launch. The 9-way adjustability dials in shock rebound, giving the driver control over excessive rear vehicle body separation. These cost effective shocks feature an external dial for easy adjustability. Sold individually.





### Leaf Spring Traction Bars

Competition Leaf Spring Traction Bars are designed for Stock Eliminator & bracket race cars with leaf springs. These traction bars eliminate wheel hop & improve grip by applying the force (that normally produces unwanted axle rotation) downward. Sturdy 2.5" x 2.5" x .120" wall steel tubing handles up to 450 HP. Bars are fixture welded to ensure a perfect fit for every application.

### 3-Way Adjustable Drag Shocks

Sold individually, Competition Engineering 3-Way Adjustable Drag Shocks are designed to allow the racer to dial-in the race car to meet changing track conditions.

**Front Drag Shocks** are adjustable in three ratios: 90/10, 80/20 & 60/40. You can quickly change the valve setting by simply compressing the shock fully & rotating the shaft until the indexing notch mates with the desired setting on the body. It's as simple as twist & click.

**Rear Drag Shocks** are also adjustable in three ratios: 30/70, 40/60 & 50/50. These shocks also adjust by compressing them fully & rotating to the desired setting on the body.

### Mid-Mount Engine Plates

Mid-Mount Engine Plates are designed to work with front motor plates to eliminate torsional stress within the chassis. Installation of a mid-mount plate allows for easier transmission swaps, aligns the drivetrain to stop block twisting & broken transmission cases, & provides smooth clutch operation. Welding required.



### Suspension Components

UMI Performance proudly designs & manufactures its entire line of products within its facility located in the small town of Philipsburg, Pennsylvania. UMI Performance develops a large variety of products for many makes & models of GM vehicles as well as the Ford Mustang.

- **Sway Bars**
- **Subframe Connectors**
- **Upper Control Arms**
- **Lower Control Arms**
- **Adjustable Torque Arms**
- **Control Arm Relocation Brackets**







Dirty Dingo Motorsports manufactures the most innovative LS conversion swap motor mounts & billet aluminum accessory brackets for GM LS1, LS2, LS3, LS6, LS7, LSx, & Gen III & Gen IV engines.



## Chevy LS & LT Conversion Motor Mounts

The "Dirty Dingo" adjustable motor mounts allow you to position your LS engine correctly in your engine compartment. Unlike competitors motor mounts, these "Dirty Dingo" motor mounts are slotted for adjustability with engine placement in the engine compartment allowing you to move your engine 1.0 inches forward, or 2.0 inches rearward from typical mounting locations.

GM Gen III & Gen IV LS conversion engine mounts are designed for swapping the LS engine into older muscle cars & trucks.

GM Gen V 2014 & newer LT1, LT4, L83, L86, & other Gen V small block conversion swap engine mounts are also available!

## Chevy LS & LT Conversion Brackets & Accessories

GM Gen III & Gen IV LS conversion accessory brackets are designed for swapping the LS engine into older muscle cars & trucks. Made of thick 6061-T6 aircraft billet aluminum, these brackets, pulleys & accessories compliment your LS or LT engine swap/conversion project.

*\*All LS accessories are determined by what balancer is on your engine.*

- **Power Steering**
- **Alternator**
- **Air Conditioning**
- **Idler**



### Power Steering Adapter Fitting

Custom made fitting for converting your late model power steering pressure hose to fit older style 3/8 flared fittings. Direct bolt on part. Includes viton o-ring required on late model pumps. Will fit Gen III & Gen IV LS Corvette, Camaro, GTO, CTSV, & Vortech Truck power steering pumps.



### Press Fit Power Steering Fitting

This is a tight 90 degree return fitting to give extra clearance when installing our billet LS1 alternator/power steering bracket.

*\*Press fit with 5/8 barbed fitting.*



## TRANSMISSION CROSSMEMBERS



These G-Force Performance dual exhaust transmission crossmembers eliminate clearance problems caused by routing exhaust under the stock crossmember. These heavy-duty, double hump crossmembers are manufactured from 2 in. x 3 in. steel tube with 1/2 in. plate steel. These crossmembers will also help to stiffen the vehicle's frame & assist with straight launches. They install easily with basic hand tools.

### WE STOCK A VARIETY OF GM & FORD CROSSMEMBERS!



### Mustang, Chevy Engine Bolt In Motor Mount Adapters

This adapter bolts to the factory k member, & retains all the structural integrity that was designed into your factory chassis.



### Adjustable GM Transmission Mounts

Custom Applications sometimes require a transmission to sit in a different location than stock. G-Force designed this adjustable Transmission Mount to allow between 1-2.5" of offset. Includes polyurethane bushing to absorb harsh driveline vibrations.

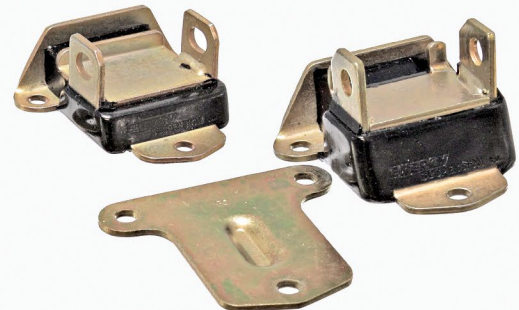
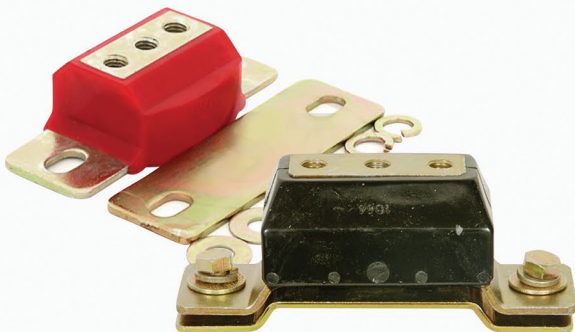

### **ENERGY SUSPENSION** Transmission Mounts

Energy Suspension polyurethane transmission mounts feature heavy duty steel hardware & polyurethane bushings. The high performance polyurethane construction provides stiffer & longer lasting performance than rubber bushings.

### **ENERGY SUSPENSION** Motor Mounts

Energy Suspension motor mounts bushings help reduce wheel hop & traction loss. These bushings are constructed from high performance polyurethane, providing stiffer & longer lasting performance than rubber bushings.





## Direct Fit & Aluminator Performance Radiators

Be Cool builds radiators in the same down or cross flow configuration as OE to avoid installation issues yet incorporates upgrades to increase cooling capacity. Downflow radiator tanks are on the top & bottom of the core; crossflow radiator tanks are on the sides. Both cool equally as long as the core surface is the same in square inches. Plus, epoxy-free assembly improves heat dissipation.

The Aluminator's crossflow design incorporates a dual core with 1" tubes & .080" thick aluminum tanks. Manufactured with OE-sized inlets & outlets in proper OE position, these direct-fit radiators replace stock units without modification. Every radiator is 100% pressure tested.

- Aluminum Construction with Natural or Polished Finish
- 40% Lighter than OE Radiators but More Cooling Power
- 100% Pressure Tested
- Compatible with All Coolants
- Direct Replacement Mounting
- OE Inlet/Outlet Size & Location



## Single, Dual, & Triple Pass Performance Radiators

**Single pass radiators** offer excellent quality at an affordable price. The lightweight 1" tubes, arranged in two rows, offer excellent cooling & make the radiators ideal for use in all types of race cars, off-road vehicles & street machines. Available to fit Ford or GM powered vehicles, standard 1-1/2" inlets & 1-3/4" outlets have beaded hose fittings. Radiators are available in 22", 24", 26", 28", & 31" widths to fit a wide variety of chassis & engine compartment configurations.

**Dual pass radiators** circulate coolant across the top half of the radiator, then back across the bottom half, allowing up to twice the heat dissipation.

**Triple pass radiators** circulate coolant across the top portion of the radiator, back across the mid-section & through the bottom allowing maximum heat dissipation.

*These radiators include furnace brazed tanks, two rows of 1" tubes, billet machined filler necks with overflow, standard 1-3/4" outlet & a universal inlet designed to accept 1-1/2" standard hose, -16 or -20AN fittings*







### Lightweight Low-Profile Electric Fans

These budget-friendly fans are thin, lightweight, & versatile for the most popular vehicle applications. They have glass-reinforced plastic blades & durable shrouds with multiple mounting points. Their high-output electric motors are also built to last. Nylon mounting ties included for a quick installation with hand tools.

- Plastic Shroud
- Durable Electric Motor
- Slim Design Ideal for Tight Spaces
- Glass-Reinforced Polypropylene Blades
- Frees Water Pump Pulley for Additional RPM



### Heavy Duty Electric Fans

These heavy duty electric fans are perfect for your heavy duty cooling needs! Features glass-filled nylon plastics with the highest temperature & impact resistance materials used in the market. All motors are fully sealed, which make them dust & waterproof. Choose the perfect size for your application. Wiring relays & thermostats are not included.



### Tornado & Dual Performance Electric Fans

**Tornado Push & Pull-Style Electric fans** boost your engines performance by drawing less amperage & reducing fuel consumption. Available with Premium Hardware, Thermostat Hardware, or Standard Mounting Hardware kits.

**High-Output Dual fans** are the best choice for any application. By removing a vehicle's belt-driven fan, you increase horsepower, torque, & fuel economy! These dual high output electric fans are some of the most proven & reliable fans available, generating the most real-world airflow in the smallest package.



Electric fans can free up to 30HP on a SBC V8 over a mechanical fan in parasitic loss!





## Electric Water Pumps

Eliminate unnecessary weight & drag at high RPM with a Proform Electric Water Pump. These high quality water pumps are manufactured from lightweight aluminum. By eliminating the belt driven mechanical pump & reducing accessory drive drag, you can increase horsepower & flow up to 35+ gallons of water per minute. This delivers the adequate cooling power your engine requires. The durable aluminum housing is available with epoxy powdercoat in a variety of finishes for great looks & corrosion resistance. The pump fitting, mounting hardware & gaskets are also included!



Electric water pumps can free up on average +10HP & +6ftlbs on SBC V8 vs mechanical pumps!



## Direct Fit Billet Electric Water Pumps

All units are CNC machined out of 6061 billet aluminum & are direct fit for Chevy, Ford, & Mopar applications. Each pump is assembled with stainless steel hardware & a carbon ceramic mechanical seal. All units will free flow 50GPM with its heavy-duty electric motor while only drawing 6 AMPS. Pumps will work with a 12V or 16V electrical system.



## Electric Water Pumps

American made with quality far superior to any other performance aftermarket company. Stainless steel large diameter main shaft with high performance ceramic seals for extreme duty use. Pumps will clear cam belt drives & most blower drives.



## High Flow Aluminum Water Pumps

Proform High-Flow Aluminum Water Pumps feature a CNC'd cast iron impeller spinning on heavy-duty ball bearings for up to 40% more coolant flow.

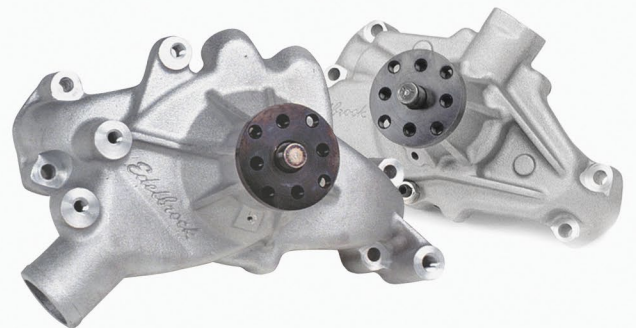

## Aluminum High Performance Water Pumps

Available for most popular applications, these High Performance pumps flow in only one direction for optimum efficiency. The casting's computer-designed internal passages & precision powdered metal impeller produce the maximum flow rate possible.



### COOL PLATE & FIN

## Remote Transmission Cooler

Mounts anywhere space permits. Electric fan supplies optimum airflow. Dramatically extends engine & transmission life. High efficiency OEM style Plate & Fin cooler, Clear anodized aluminum shroud. Transmission cooler kit includes fan mounted cooler, two -6AN fittings & four -6AN x 3/8" hose barb fittings, 180°F In-line thermostat, 10 ft. of OEM spec hose, 5/16" Insta-dapt radiator fitting, 5/16" & 3/8" compression fittings, & hardware -



### SUPER COOLER & HI-TEK

## Transmission & Oil Coolers

Automatic Transmission SuperCoolers are designed with a "Low Pressure Drop" feature that uses 3/8" hose barb ends with a unique bypass that allows a controlled amount of transmission fluid to bypass the stacked plate core when the fluid is cold. This is beneficial in cold climates to guard against lube system failure. Viscosity controls the transmission fluid & returns it directly to the lube circuit through bypass openings in the stacked plate core.

Universal SuperCoolers contain 1/2" NPT fittings & are adaptable to steel braided lines & AN fittings. These plate & fin coolers are 1-1/2" thick for extreme efficiency. Suitable for all fluid cooling needs including: automatic transmission fluid, engine oil, differential fluid, power steering & turbocharger oil in circle track, road racing, off-road, tractor pulling & monster truck applications.

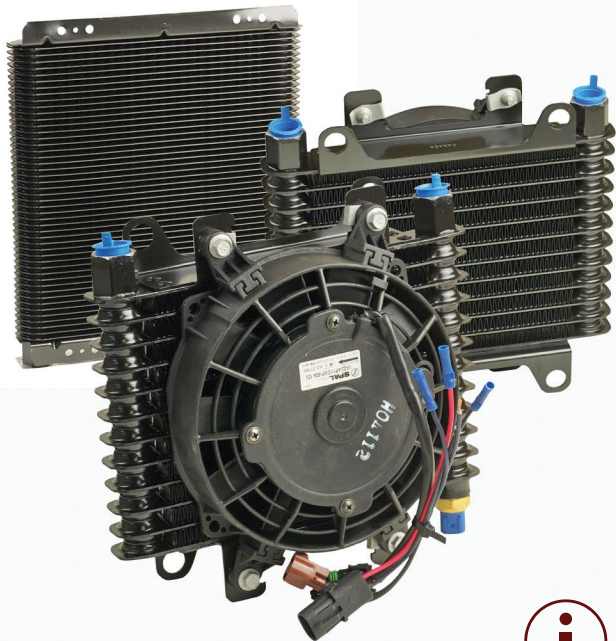

Stacked style oil coolers are the most thermally efficient design with little or no restriction in flow!



## Waterless Coolant

With a boiling point above 375°F, you can expect to eliminate the chance of overheating your motor. The lack of water also ensures you will not have to deal with corrosion & pump cavitation.



## High Performance Thermostats

Edelbrock thermostats are designed to ensure consistent cooling in high-performance applications. These thermostats feature a brass & copper valve assembly with a stainless steel body for durability. They are bolt-on OE style replacements & will fit many popular domestic & import applications.



## Low Temp Thermostats

With the JET Performance 180° Low Temp Thermostats you get consistent engine cooling & a precise metering of water throughout the engine. The JET Performance Low-Temp Thermostat is constructed of stainless steel.





### Header - Catback - Axleback Exhaust Systems

Fully mandrel bent 16-gauge aluminized steel tubing. American Thunder features a very powerful aggressive tone, Force-II is a 3-chamber muffler design, which still provides a powerful tone, but not as aggressive as the American Thunder series. Some systems include polished stainless steel tips. All hangers are in the OEM locations for a direct, easy fit. Includes all necessary hardware & clamps for a complete installation.

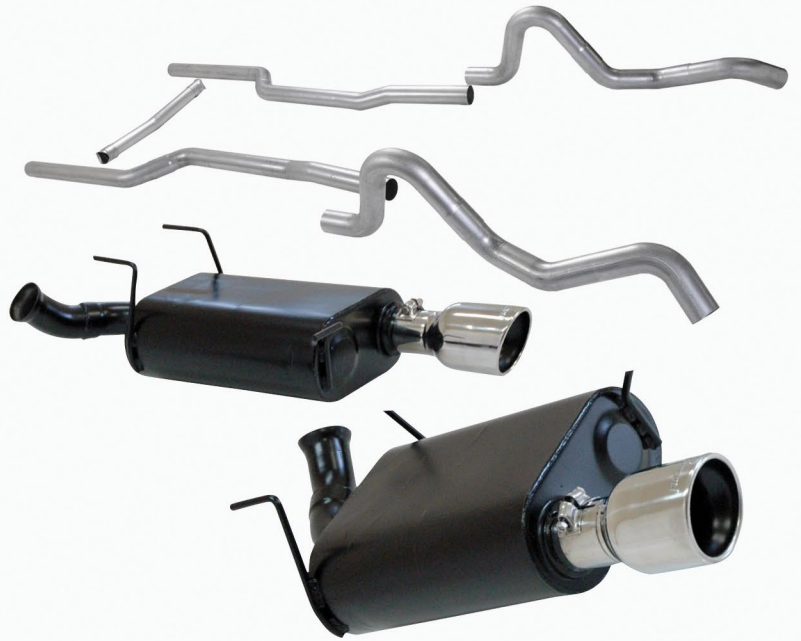

### Scavenger Series Headers

Manufactured from 409S stainless steel & ceramic coated for maximum durability. Ball & socket collector flange for a gasket-free leak-proof seal. Dyno tested performance. Designed for an easy fit, these headers include gaskets & necessary hardware. 3/8" thick laser cut flanges.

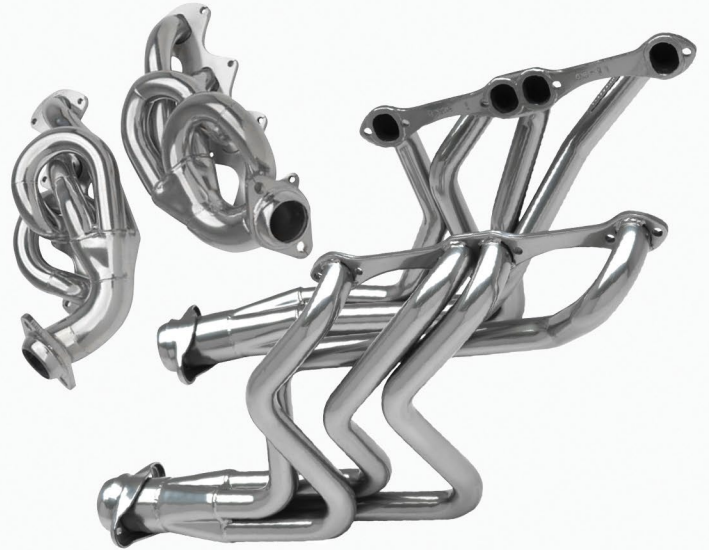

### Performance Mufflers

100% stainless steel & lap-joint welded for solid construction & rugged reliability even in the most extreme conditions. Free-flowing, straight-through perforated stainless steel core, stainless mesh wrap & acoustical fiber fill to deliver that smooth, deep tone. Vehicle specific systems are also available!





### Stainless Steel Exhaust Systems

Fabricated using the highest quality materials, 16GA, mandrel-bent, stainless steel pipe ensures maximum exhaust gas flow, which can significantly boost horsepower. Designed to deliver enhanced performance, provide extra punch in the passing lane & improve gas mileage. X-Change feature allows use of direct bolt-in electric exhaust cutouts off of the X-Pipe. Systems do not include mufflers so you can custom tailor your system for your specific street or race application.

### Violator Mufflers

The Violator's aggressive sound is the result of a unique internal louvered tube with mini sound deflector chambers utilizing Pypes Slingshot technology. This configuration also dramatically reduces unwanted internal cabin resonance too! PYPES Violator Mufflers are made from 409 stainless steel to ensure longevity.



### Stainless Steel Performance Mufflers

Full stainless steel construction, & seam welded for years of high flow performance. Provides a deep, powerful aggressive growl that wakes up the exhaust tone of virtually any engine, 4cyl, 6cyl, 8cyl, 10cyl & even 12cyl! Reversible, straight through flow design provides extreme flow & minimal back pressure.

### Exhasut Tips

Highly polished, thick-walled stainless steel exhaust tips. Give your exhaust that finishing touch! Will not chip, peel or crack over time like chrome tips. Many styles & sizes to choose from. Sold individually.



### Electric Exhaust Cutouts

Go from stealth quiet to wide open power at the flick of a switch! Run it fully open, closed or anywhere in between. Available wireless remote kits work from 100 feet away. CNC 6061 aircraft aluminum bodies. Full metal motor cover/ powder coated satin finish. Stainless steel butterfly plates & shafts. 6061 aircraft aluminum motor plates. High torque DC gear driven motor. Gears are made from high temp steel for long life. 2 position momentary toggle switch. Weather proof wiring harnesses. Weather tight connectors for superior sealing.



See our QTP EZ Kits available!





## GASKET KITS & SETS

Remflex Inc. specializes in exhaust gaskets, including header gaskets, collector gaskets, & exhaust flange gaskets. Featuring a unique flexible graphite material, Remflex gaskets have offered proven sealing in industrial applications where temperatures routinely exceed 2,000 degrees. We stock a full selection of Remflex exhaust system gaskets for a wide range of applications!

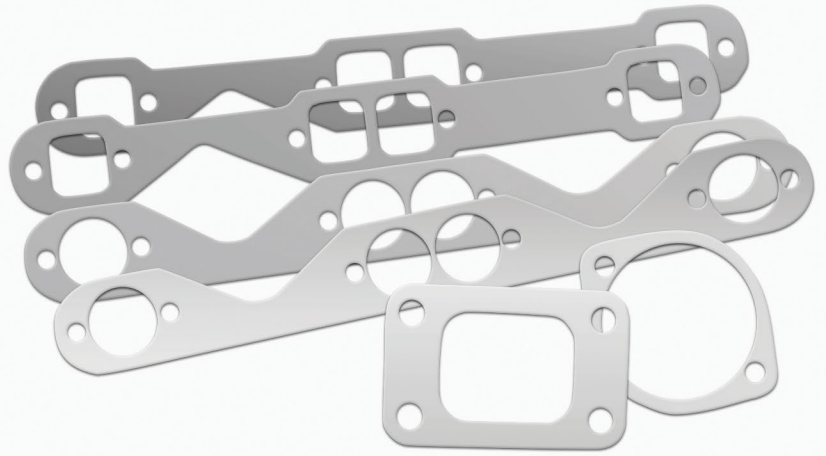

## GASKET KITS & SETS

Fel-Pro is the world's leading manufacturer of replacement gaskets & sealing products for cars, trucks, marine, performance, & severe-duty applications. Fel-Pro engineers continually push the envelope with sealing science, developing innovative products like PermaTorque, Loc Wire, & PermaDry gaskets—that same engineering goes into every product Fel-Pro makes from complete engine gasket sets to valve stem seals, so you can trust the sealing solutions from Fel-Pro.

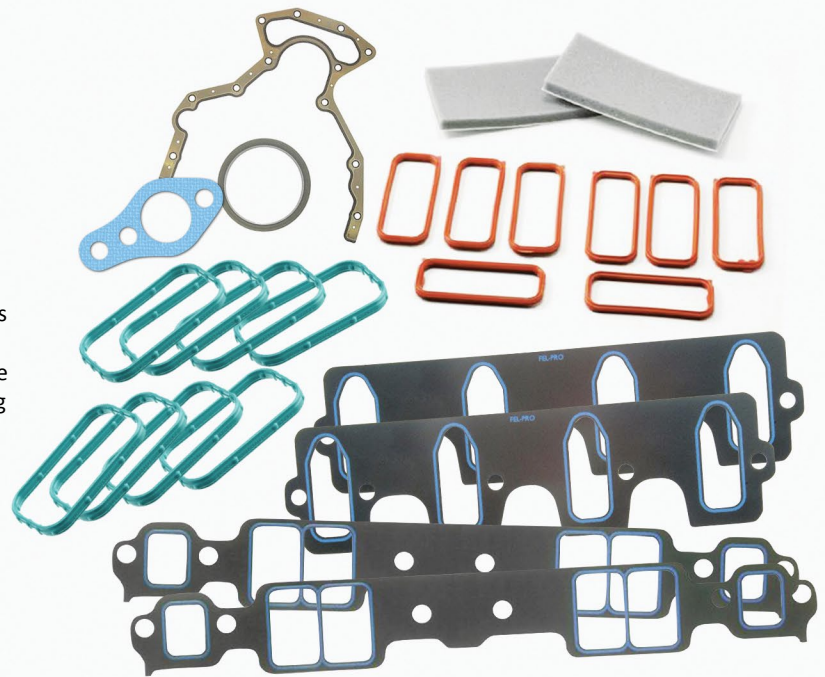

## GASKET KITS & SETS

BBK Performance Parts Premium Header Gaskets are made from durable graphite to ensure lasting, leak-free service. All header gaskets are designed to match BBK's free-flowing header flanges for optimum, long-lasting performance. Sold in pairs.

These BBK throttle body gaskets are ideal for new installations, maintenance work or rebuilds on your fuel injection system.

- Made from Premium-Quality Composite
- Excellent Seal
- Perfect Fit

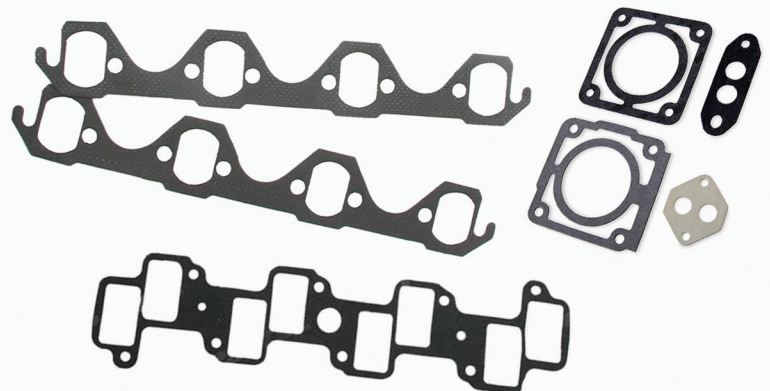



## Supercharger Head Units

From 8-rib drive to full race cog drives. ProCharger produces a head unit that will suit your application & horsepower level. Self-contained oiling within the head unit. The highest step-up ratio, exclusive billet impellers, & the industry's only billet gearcases for superior rigidity, sealing & appearance. Call us today for pricing & availability on full systems for carb'd & late model car & truck applications! RaceDrive units run the supercharger directly off the crank with different clocking positions available.



### Carburetor Hats

This attractive, all-new ProCharger design provides 10% more airflow than the standard carb bonnet, as well as improved air/fuel distribution with a lower height for improved hood clearance.



## Performance Turbo Chargers

Precision's line of turbochargers are engineered specifically for today's wide array of vehicles. Standard SC series turbos feature a T31 Hi Flow turbine housing with a CNC machined Precision T04E style compressor cover that's been redesigned for maximum efficiency. Provisions for an integral wastegate are optional.

Many different models are available for power levels ranging from 350 to 2500 horsepower!



## Universal Black Intercoolers

S Line - Large 3" thick core & 3" inlet/outlet provides optimal flow & volume for high horsepower vehicles. Overall size: 23" x 12" x 3"

Z Line - 2.5" thick core & 2.5" inlet/outlet provides optimal flow & volume for high horsepower vehicles. Overall size: 28" x 7.5" x 2.5"

R Line - Massive 4" thick core & 3" inlet/outlet provides optimal flow & volume for high horsepower vehicles. Overall size: 31" x 12" x 4"





## Proflow, Bullet, & Race Bypass Valves

More horsepower means more airflow. To avoid compressor surge, potential damage to your supercharger & prevent throttle hanging or belt snapping, you need a consistent, reliable surge valve designed for your horsepower level.

ProCharger has multiple bypass valve models available based on the specific needs of your application.



## **TiALSPORT**

### Q 50mm Blow Off Valves

Fully CNC-machined 6061 aluminum. Teflon lubricated Viton O-ring seal. Includes an aluminum & steel mounting flange. V-Band aluminum mounting clamp.

### V60 Series 60mm Wastegates

The largest unit in the TiAL lineup. This massive 60mm wastegate will control boost with dead on accuracy in the most demanding situations.



### Turbo Shield Blankets

Provides the ultimate means of reducing turbo lag while serving as a superior heat barrier. Made from pulverized volcanic rock then strained into a fiber material. Withstand direct heat up to 1800°F & 2500°F radiant heat. Hi-temp rated silica insulation padding under the tight outer layer for extra added protection against extreme turbo-generated heat.



### Bolts, Head Studs, Fasteners & More

Since 1968, Automotive Racing Products has been engineering and perfecting bolts, studs, nuts, and other fasteners for engines, cylinder heads, headers, wheels, transmissions, and more. Largest IN STOCK selection of ARP racing hardware on Long Island!



### Turbo Inlet & Discharge Flanges

We stock a large assortment of both Mild Steel & 304SS Turbo Flanges for your custom fabrication projects. Each flange is precision Laser Cut & CNC Machined to ensure a perfect fit to your turbo components. Choose from our extensive line up of Turbo Inlet Flanges for manifold fabrication, Turbocharger Discharge Flanges for custom downpipes, available in high quality 304 Stainless Steel or Mild Steel.

# FABRICATION MATERIAL & SUPPLY



Aluminum & Stainless Steel Piping  
**1.5" - 5" Straight sold by the foot**

Aluminum & Stainless Steel Piping  
**45°, 90°, u, & J Bends Available**

We are your one stop shop for fabricating custom exhaust & piping setups. From intercooler to exhaust setups, we have an extensive stock of material!



## V-Band Clamp & Tube Flanges

For a leak-free easy-to-use system, these V-band clamps with CNC'd flanges are ideal for vehicles that undergo frequent maintenance or power adder applications where exhaust pressure is much higher than normally aspirated vehicles. Welding required. Collars and clamps also available separately.



## 4-Ply Silicone Hose bends & Couplers

4-ply Silicone Bends, Adapters, + Couplers 45°, 90° bends 2" - 4" Diameters



## Pneumatic air line fittings

Straight + 90° Fittings, Unions + tubing by the foot





## Forged Dynalite Front & Rear Big Brake Kits

DynaPro 6 forged billet calipers are combined with 12.19" diameter rotors for this group of traditional non-ABS spindles on American muscle cars & vintage rods.

FDL Pro-Series rear disc kits provides a complete solution for popular muscle car rear axles that require a parking brake. Forged billet Dynalite four piston calipers, 12.19" one-piece drum/rotors, & high friction pads provide optimized & balanced braking for all types of custom performance street/strip & show machines.



## Aluminum Tandem Master Cylinders

Wilwood's Tandem Aluminum Master Cylinder is available in 4 bore sizes 7/8", 15/16", 1.00" & 1-1/8"; & 3 finishes, plain, ball burnished & black e-coat.



## Street/Strip Forged Wheels

**RTS** has the classic WELD Racing look & continues the WELD Racing tradition utilizing a forged billet center & cold forged rims. This unique wheel offers 3 mounting pad heights to clear specific drum & multi-piston opposed calipers.

**Draglite & Prostar** Sport Forged Wheels have long offered the best strength to weight ratio & lowest rotational moment of inertia of any mid priced hot rod forged wheels for maximum performance.



## ET DRAG & ET STREET TIRES

A Proven Drag Strip Winner Real world research & development give **M/T® Drag Slicks** the edge over competitive brands. Engineered for maximum traction & consistent ET's with superior construction & compounding for nearly every drag race application.

**ET Street S/S & R Tires** can be driven on the track, the ET Street S/S from Mickey Thompson is a high performance street to strip tire with radial construction, R2 compound & more; 15- to 20-inch fitments.



▶ Sizes range up to 33" tall; widths up to 16.5" for 15" wheels.

▶ Sizes range 255/60R15 - 335/25R20



# SPECIALTY TOOLS



## Manual Piston Ring Filer

Enables the user to file piston rings quickly & accurately. Position the piston ring firmly against the dowel pins, crank the handle to turn the abrasive wheel. Using a feeler gauge, file the piston ring to meet the manufacturer's specification.

## Electric Piston Ring Filer

Accurately set end gap with Proform's powerful electric ring filing tool. Powered by a 12 volt, rechargeable battery. Comes with two (2) 120-grit grinding wheels & battery recharger. Portable or can be bench mounted.



## Dual Gauge Leakdown Tester

This dual-gauge leakdown tester measures the condition of your head gaskets, piston rings, & valves. A must to test your internals before going to forced induction or nitrous! The left gauge records incoming air pressure, & the right gauge records individual cylinder pressure - & the difference is your leakdown.

## Dial Indicator

Universal Dial Indicator, graduation: 0.001". Can be used on a cam checking tool, a magnetic dial indicator base, or a deck bridge, for finding top dead center & other measurements.



## Magnetic Deck Bridge

Will fit over any cylinder bore up to 4.500". Designed to check piston-to-deck clearance, as well as piston position at top dead center. Strong magnet holds it firmly in place.



## Harmonic Balancer Installer/Puller

Fits all Ford, GM, & Chrysler engines that use 3/4 x 16 shaft; also includes 7/16 x 20, 5/8 x 18, 1/2 x 20 adapters. This heavy-duty professional tool, equipped with roller thrust bearings, can also be used as a universal puller! May also be used for steering wheel & pulley installation & removal.



## Valve Spring Compressor

Stud mount design fits 3/8" & 7/16" rocker studs. Removes valve spring from an assembled engine for checking or replacing quickly & easily. Press down to compress coil spring, then remove valve keepers. Release slowly.



## Universal Cam Degree Wheel

Contains all the tools needed to degree cams in the most popular engines. Features deluxe components including 9" degree wheel, dial indicator, dial indicator mount, 2 valve check springs, clamp kit, 14mm top dead center locator, wire degree wheel pointer, detailed instructions, & a durable foam padded carrying case. For use with heads on engine.





## SINGLE & MULTI LAYER JACKET & PANTS

**GF125 Single-Layer Jackets & Pants** meet SFI 3.2A/1 rating & carries a TPP rating of 11. Avail. in **Sizes M - 3XL**

**GF505 Multi-Layer Jackets & Pants** have an SFI-5 rating & carries a TPP rating of 26. Avail. in **Sizes M - 3XL**

**GF545 Double Layer Jackets & Pants** meet SFI 3.2A/5 rating & carries a TPP rating of 23. Avail. in **Sizes M - 3XL**



## RACING GEAR

### SF3 Full Face Helmets

Snell SA2015 Certified. Lightweight Composite Shell. ProFit Shield with 5 shield ratchet positions. Flame Retardant Liner. G-FLOW Ventilation System. Reinforced mounting points for Helmet Restraint Devices. **Sizes M-2XL**

### GF236 Pro Series Racing Shoes

Radial-Grip treaded sole, made with Carbon Fiber. Meets SFI 3.3/5 rating. **Sizes US Mens 10-12**

### Black/White Racing Gloves

Premium Nomex knit & premium leather are used to make the G1 RaceGrip gloves. G-Force uses a special lightweight flame retardant fabric that wicks moisture away from the hands while giving the racer that exclusive RaceGrip feel. SFI 3.3/1 Rating. **Sizes L - 2XL**



## 5-Point Racing Harnesses

Black 5-point harness. Required for all 11.99 ET & quicker vehicles. 3" belt with latch & link system. Meets SFI 16.1 specs. Roll bar mount.



## HalGuard™ Premium Clean Agent Auto Fire Extinguishers

HalGuard™ is no ordinary automotive fire extinguisher. It contains Halotron® 1, electrically non-conductive "clean" extinguishing agent that rapidly turns into a gas.

Hand held HalGuard™ extinguishers are available in either compact 1.4 lb. and 2.5 lb. sizes.





## Leaded, Unleaded, Methanol, & Small Engine VP Racing Fuels

VP Racing Fuels is best known as the World Leader in Race Fuel Technology™, fueling champions around the world in virtually every form of motorsport on land, sea & air since 1975. VP's fuels have a well-earned reputation for offering more power & unparalleled consistency.

**i** Authorized **Dealer - 5 Gallon Pails IN STOCK**

LEADED BLENDS	
C12 Race Gas	112.5
C14 Race Gas	116.5
C16 Race Gas	120+
C23 Race Gas	120+
C25 Race Gas	118
Q16 Race Gas	120+
X16 Race Gas	116
VINTAGE Race Gas	98
NO2 Race Gas	120+
U4.4 Race Gas	108.5

UNLEADED	
C9 Race Gas	96
X85 Ethanol Blend	105
X98 Ethanol Blend	115
VP100 Unleaded	100
MS109 Race Gas	105
Unleaded Extreme	110.5
C85 Race Gas	98
T4E Unleaded	100

METHANOL BLENDS	
Nitro/M1 50/50 (1 Gal.)	
Nitro/M1 50/50 (5 Gal.)	
M1 Methanol	
M3 Methanol	
M5 Methanol	

SMALL ENG. FUEL	
4 Cycle (1 Gal.)	
4 Cycle (1 Qt.)	
SEF 40:1	
SEF 50:1	



## Race Gas

Race Fuel Concentrate

### Race Fuel Concentrate

A potent & powerful molecular blend creates this Race Fuel concentrate. The highest quality MMT is used for the upmost in true octane results. Take your ordinary pump gasoline & transform it into high octane, high energy, track grade racing fuel. Unleaded formula is safe for all sensors. For all motorsports requiring the highest horsepower producing fuel concentrate.



### Accelerator Concentrate

Accelerator is a blend of components which will transform the make up of premium unleaded pump gas to closely resemble race fuel. Won't harm sensitive O2 sensors or catalytic converters.



### Lucas Oils, Lubricants, & Additives

Lucas Oil has developed many new, innovative & top performing lubrication & additive products. Lucas has a tremendous research laboratory where they can develop & test products to determine their consistency & quality. Lucas lubrication products are made to withstand the harshest environments



### Redline Performance Oils & Additives

Red Line formulates chemically-advanced additives using the world's finest base stocks. Red Line's complete array of Fuel System Additives & Cleaner products offer unprecedented value with concentration to treat larger fuel volumes at a lower cost





# STOP RUST PERMANENTLY PAINTS, ENAMELS, PREP & REPAIR



## TOP COAT OVER POR-15

Non-porous & will not crack, chip, or peel. Available in Gloss Black, Semi-Gloss Black, Silver, Safety Red & White. 1PT, 1QT, & 14 OZ



## POR 15 RUST PREVENTIVE PAINT

High-tech, high performance rust-preventive coating. Available in Gloss Black, Semi-Gloss Black, Gray, & Silver. 4OZ, 1PT, 1QT & 1 GALLON

## POR 15 SUPER STARTER KITS



Includes a 4 oz. can of Gloss Black (enough to cover 6 square feet with 2 coats), a half-pint of Metal Prep, 2 wooden handle paint brushes, & a pair of high-dexterity surgical latex gloves, PLUS an 8-ounce bottle of Cleaner Degreaser.



## HIGH-TEMP HEADER PAINT

POR-15 High Temp Paint is capable of withstanding extreme temperatures up to 1200°F & will resist cracking, chipping, & peeling. It is also extremely weather, salt & moisture resistant.



## ENGINE ENAMELS

Enamels are available in incredibly rich colors that flow easily, cover better than any other paint, & last longer. Ask about Make/Model specific colors!



## BRAKE CALIPER PAINT KITS

Kit includes 1 Qt. of caliper cleaner, 8 oz. caliper prep, 4 Oz. Rust preventive Paint, 1 Roll of masking tape, 2 pairs of gloves, 2 foam brushes. Detailed Instructions Included.

Black, Red, Yellow, Blue, Red



## FUEL TANK REPAIR KITS



## METAL PREP

Quart | Gallon



## CLEANER DEGREASER

Quart | Gallon



# Gasket Makers, Epoxies, & Threadlockers



## Ultra Black RTV Silicone Gasket Maker

3.5 OZ



## The Right Stuff Black Instant Gasket Maker

10 OZ



## Temp Ultra Copper Silicone RTV Gasket Maker

3 OZ



## Ultra Black RTV Silicone Gasket Make

13 OZ



## Spray-A-Gasket High Tack Gasket Sealant

12 OZ



## Ultra Slick Engine Assembly Lubricant

4 OZ



## Dielectric Tune Up Grease

Protects Electrical Components!

.33 OZ



## High Temperature/High Strength Threadlocker Red

6 ML



# HIGH PERFORMANCE OILS & LUBRICANTS

Long Island's Largest Selection of IN STOCK Performance Oils & Lubricants!

Top-quality automotive oil, fluids, & lubricants to assemble & maintain all engine types. From conventional to synthetic to racing motor oil, your vehicle isn't going anywhere if the engine isn't properly lubricated.





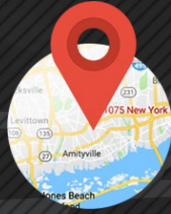

**1075 Route 109**

Lindenhurst N.Y. 11757

Sales: **800.846.4252**

Engine Shop: **631.957.5130**

### Superstore Hours

**SUNDAY**  
**10AM - 4PM**

**MONDAY - FRIDAY**  
**9AM - 7PM**

**SATURDAY**  
**9AM - 5PM**

Shop 24/7 at:

**WWW.SKSPPEED.COM**



**LARGEST STOCK!**  
on the East Coast



**VP FUEL & NITROUS!**  
Your IN STOCK Source



**LOCAL EVENTS!**  
hosted by SK Speed